

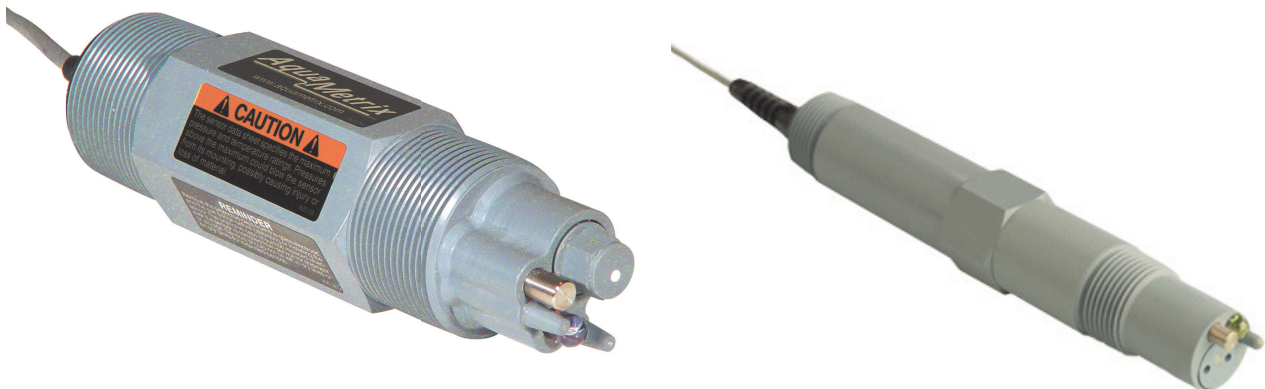

OPERATING INSTRUCTION MANUAL



MODEL P/R65 DIFFERENTIAL 2-WIRE (4-20 mA) pH & ORP PROBES

N116-139 REV. 0

Aquametrix, by Water Analytics Inc.
100 School Street
Andover, MA 01810

Tel: (978) 749-9949
Toll Free: (855) PH-PROBE
Fax: (978) 749-9961
www.AquaMetrix.com

TABLE OF CONTENTS

1. GENERAL INFORMATION	3
2. SPECIFICATIONS	4
3. INSTALLATION	5
3.1. GENERAL INSTRUCTIONS	5
3.2. CONNECTING THE P/R 60 TO A PLC OR AQUAMETRIX 2300	5
3.3. ORP (R65) 4-20 MA PROBES	6
3.4. SUBMERSION MOUNTING SERIES 8 DIFFERENTIAL PROBES	6
3.5. SUBMERSION MOUNTING SERIES 6 DIFFERENTIAL PROBES	6
3.6. FLOW-THROUGH TEE MOUNTING SERIES 8 DIFFERENTIAL PROBES	6
3.7. FLOW-THROUGH TEE MOUNTING SERIES 6 DIFFERENTIAL PROBES	7
3.8. SANITARY PROBE P65S, R65S, P65C5-S, R65C5-S	7
3.9. INSERTION MOUNTING SERIES 4 DIFFERENTIAL PROBES	7
3.10. HOT/WET TAP INSERTION MOUNTING SERIES 7 DIFFERENTIAL PROBES	7
4. SERVICE AND MAINTENANCE	7
4.1. PROBE CLEANING	7
4.2. REPLACEMENT OF SALT BRIDGE FOR SERIES 4, 5, 6, 7 & S DIFFERENTIAL PROBES	8
4.3. REPLACEMENT OF SALT BRIDGE FOR SERIES 8 DIFFERENTIAL PROBES	8
4.4. STORAGE	9
5. TROUBLESHOOTING AND SERVICE	10
5.1. CHECKING PROBES P65 AND R65	10
5.1.1. P65 PH PROBES	10
5.1.2. R65 ORP PROBES	10
5.2. TROUBLESHOOTING	11
5.3. CUSTOMER SERVICE	11
5.4. PARTS AND ACCESSORIES	12
6. DRAWINGS	14

1. GENERAL INFORMATION

This manual covers all AquaMetrix P65, and R65 Series differential measurement pH and ORP probes.

The PRR65 series probes feature the Aquametrix differential design for long lifetime, user serviceability and more accurate readings. In typical installations these probes will last for years whereas the more common combination probe lasts only months. The “P” prefix refers to the pH probe while the “R” prefix refers to the ORP version.

The P/R65 probe is a 2-wire device. It incorporates an encapsulated transmitter that outputs a 4-20 mA analog signal. It was designed to connect directly to a PLC or the AquaMetrix 2300 multi-input controller.

The output from a two-wire transmitter type is non-isolated and un-calibrated. The system must provide 24 VDC, with the “low” input isolated from earth ground, and a means of calibrating for offset and span.

NOTE: Do not discard the protective cap(s) that came with the sensor. If the sensor is removed from the process for an extended period of time, thoroughly clean the sensor, put a piece of cotton ball with few drops of water into the protective cap and replace it on the sensor. This keeps the junction from drying out which causes slow response when put back into operation or causes permanent damage to the sensor. **Sensors should not be left in dry lines or empty tanks for extended periods.**

Do not store the sensors in a dry or humid location. When storing, check the protective cap(s) regularly to make sure the cotton ball remains moist. Improper storage of sensors voids the warranty.

2. Specifications

	pH (P65C-X)	ORP (R65C-X)
Measurement Range	0 to 14.00	0 to 1000 mV or -500 to +500 mV
Wetted Materials	CPVC, Kynar/ceramic, titanium, Viton	CPVC, Kynar/ceramic, titanium, Viton, Platinum
Stability	0.03 pH/day	2 mV/day
Resolution	0.01 mA	± the greater of 0.1% of range or 2 mA
Sensitivity	< 0.005 pH	< 0.5 mV
Output Span	1.14 mA/pH	1.6 mA/1000 mV
Output Offset	12±1 mA @ pH 7	0 to 1000 mV: 12 mA @ 500±1 mV -500 to 500 mV: 12 mA @ 0±1 mV
		-500 to 500 mV: 12 mA @ 0±1 mV
Mounting	1.5" NPT	2" NPT
Flow Rate	3 m/sec (10 ft/sec). Flow should be as low as possible in water with low conductivity water or suspended solids	
Maximum Load	450 Ω	
Temperature Limits	-5 to 95°C (23 to 203°F)	
Pressure Limits	100 psig @ 65 °C, 40 psig @ 95°C	
Power Supply Limit	24±4 VDC	
Probe Cable	15 ft. (4.6 m)	
Transmission Distance	3000 ft (900 m)	
Automatic Temperature	300 Ω NTC thermistor or 1000 Ω RTD	

3. INSTALLATION

3.1. General Instructions

Specific instructions for each type of probe are given in the following pages. Common to all probes are the following instructions:

1. If the distance between the probe and the instrument is such that a direct connection is not possible, the probe cable should be routed to a junction box with a terminal strip (AquaMetrix Part No. JB1). The box should be well sealed and away from corrosion danger. Be sure that you have sufficient slack cable to allow for probe removal for calibration and servicing.
2. Route the interconnect cable from the junction box to the instrument, preferably in metal conduit. Do not run the power cable or control cables in the same conduit with the probe interconnect cable.
3. Remove the protective plastic caps from the end of the probe before placing in service.
4. For best results probes should always be mounted vertically with electrodes down. If this is not possible, the probe must be at least 15° above horizontal.

3.2. Connecting the P/R 60 to a PLC or AquaMetrix 2300

1. Refer to Figure 1 for configuring the probe for operation with a PLC or the AquaMetrix 2300 multi-input controller.
2. For connecting to a PLC (or ammeter) with a separate 24 VDC power supply the wiring between the PLC and power supply is in series as shown on the left side of to Figure 1. Note that some PLC's as well as the AquaMetrix 2300 controller have powered inputs that eliminate the need for an external power supply. The right side of to Figure 1 shows the connections to the analog connector of the 2300.

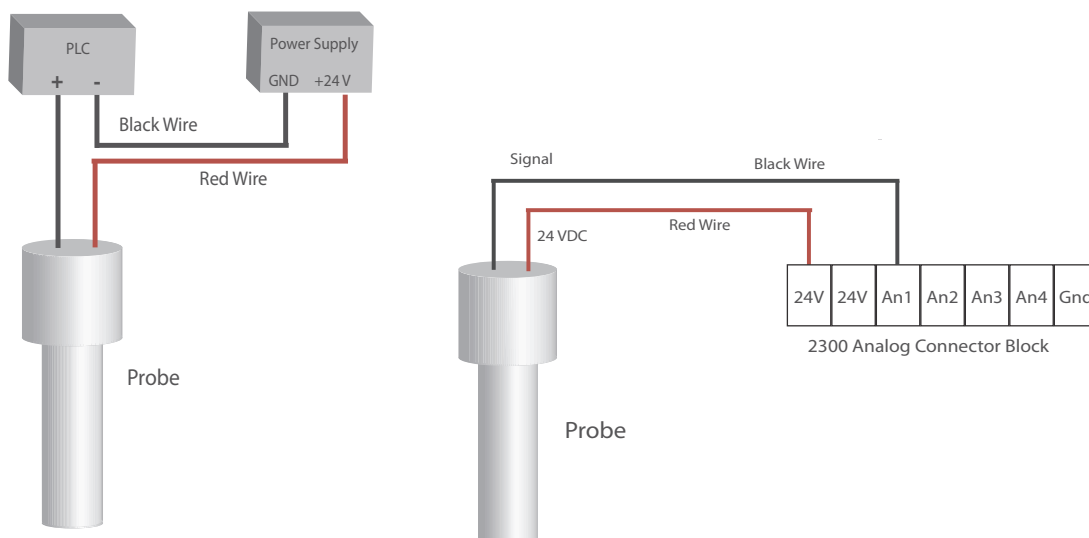

Figure 1 - Left: Electrical connections for the P/R65, with a 24 VDC power supply and a PLC. Right Electrical connection for the P/R65 with the AquaMetrix 2300 controller or a PLC with

3.3. ORP (R65) 4-20 mA Probes

1. ORP 4-20 mA probes have four wires; black, red, green and white. The red wire is to be connected to the +24 VDC terminal and the back wire to the 24 VDC common terminal via the load in the loop.
2. For an instrument with a range of 0 to 1000 mV the green and white wires are to be shorted.
3. For an instrument with a range of –500 to 500 mV the green and white wires are to be isolated from each other.

3.4. Submersion Mounting Series 8 Differential Probes

1. Refer to Figure 5.
2. A submersion mounting kit, STC60L is available from Water Analytics which includes 4 ft. of 1" pipe, 1-1/2" x 1" reducer, a strain relief fitting and wire mounting bracket. Proceed as follows, either with the kit or with your own hardware.
3. Apply a thread sealant to the thread on the cable end of the probe and screw a 1-1/2" x 1" NPT reducer onto the probe. Route the sensor cable through an appropriate length of 1" pipe and using thread sealant, screw the pipe into the reducer. The cable end of the probe should not be exposed to the process. A cable strain relief fitting should be used on the upper end of the pipe. In the kits a wire bracket is provided to aid in supporting the assembly.

NOTE: An optional protective shroud, Part No. PROTECTOR-3 should be used on the electrode end of the probe to protect the electrodes from accidental contact with the tank bottom, sides or objects in the process.

3.5. Submersion Mounting Series 6 Differential Probes

1. Refer to Figure 4.
2. A submersion mounting kit, STC60-6 is available from Water Analytics which includes 4 ft. of 1" pipe, 1-1/2" x 1" reducer and a strain relief fitting. Proceed as follows, either with the kit or with your own hardware:
3. Install the optional protective shroud, Part No. PROTECTOR-6 on the probe by threading the probe cable through it. The shroud will contact the shoulder on the probe.
4. Install the compression fitting components on the probe in the order shown in the drawing below so that the pipe thread is towards the cable end of the probe. If you are concerned that the shroud may get pushed up and expose the electrodes you can lock it down by the positioning of the fittings.
5. Snug up the nut of the compression fitting to locate it in the desired position. Hand tighten as much as possible, then turn 1/2 turn with a wrench.
6. Apply a thread sealant to the pipe thread portion of the compression fitting and screw a 1-1/4" x 1" NPT reducer to it.
7. Route the sensor cable through an appropriate length of 1" pipe and using thread sealant, screw the pipe into the reducer on the probe. The cable end of the probe should not be exposed to the process.

3.6. Flow-through tee mounting Series 8 Differential Probes

1. Refer to Figure 5.
2. Apply pipe sealant to the electrode end of the probe and screw it into the AquaMetrix union tee w/ adaptor (Part No. AM-MH538N9A) or any standard 1-1/2" NPT tee.

3.7. Flow-through tee mounting Series 6 Differential Probes

1. Refer to Figure 3.
2. Take the compression fitting apart. Apply pipe sealant to the 1-1/4" NPT thread and screw this part into a 1-1/4" tee. A larger tee with an appropriate reducer may be used.
3. Put the compression fitting components on the probe in the order shown in the drawing. They should be in such a position that the electrodes will be in the pipe stream but not touching the opposite side of the tee.
4. Remove the protective cap from the probe and place the probe in the tee. Now tighten the nut by hand as much as possible, then turn 1/2 turn with a wrench.

3.8. Sanitary Probe P65S, R65S, P65C5-S, R65C5-S

1. The P65S is designed with a stainless steel flange to mate with a Tri-Clover ferrule TL14AM7-2-1/2.
2. The P/R65CS can be replaced by the P65C5-S, which is a P65C5 with a 1" sanitary flange.

3.9. Insertion mounting Series 4 Differential Probes

1. Apply pipe sealant to the electrode end of the probe and screw it into the any standard 1-1/2" Male NPT.

3.10. Hot/Wet tap insertion mounting Series 7 Differential Probes

1. Refer to Figure 4.
2. A ball valve assembly, P-HTC, is available from AquaMetrix which includes the ball valve and safety shroud.
3. Mount the ball valve assembly in a desirable location. The assembly comes with a field selectable, 1-1/4 NPTF or socket adaptor. Make sure valve is in the close position before mounting.
4. Remove the union body by turning the union nut counter clockwise. Take the compression fitting apart as shown on the drawing. Insert the back end of the series 7 probe through the union body until safety notch on the probe aligns with the safety stop on the union body.
5. Place the union body, with the probe attached, back into the ball valve assembly and tighten union nut. Open ball valve & slide the probe into the process.
6. Put the compression fitting components on the probe in the order shown in the drawing and tighten the nut by hand as much as possible, then turn 1/2 turn with a wrench to keep probe in place.
7. Insert protective shroud as shown.

4. SERVICE AND MAINTENANCE

4.1. Probe Cleaning

1. The probe should be kept reasonably clean to avoid measurement errors. Frequency of cleaning can only be determined by experience. To clean proceed as follows:
2. Rinse with clean warm water.
3. Soak the end of the probe in warm water and dish detergent for 3 or 4 minutes.

4. Brush the end of the probe, particularly the three electrodes with a soft bristle brush such as a toothbrush. Take care not to scratch the glass electrode.
5. If the probe is still not clean, it may have to be cleaned with acid. *CAUTION: Do not acid clean probes used in processes containing cyanide solutions.* Some experimentation may be required to determine the most suitable acid for your process. Use the most dilute acid, which is effective. Normally 10 parts of water to one part muriatic acid is sufficient. *Do not use hydrofluoric acid.*
6. Soak the probe for not more than 5 minutes in the chosen acid; then rinse thoroughly with clean warm water and soak in water for 3-5 minutes.

Calibrate the system in accordance with the instrument instruction manual.

4.2. Replacement of Salt Bridge for Series 4, 5, 6, 7 & S Differential Probes

1. If the system cannot be calibrated after cleaning the probe, it may be necessary to replace the standard cell solution. A kit is available from Water Analytics for this purpose (Part No. C35-17K). Proceed as follows: Refer to DWG N106-60.
2. Hold the probe vertically with the sensor face up. Insert long nose pliers in the blind holes in the salt bridge and turn counter-clockwise taking care not to damage the glass electrode. Discard the used salt bridge.
3. Up-end the probe and pour out the contents of the standard electrode chamber. Flush the chamber with a small amount of pH 7 buffer or clean water.
4. Refill the chamber with 7pH buffer solution up to the tip of the electrode inside the chamber. DO NOT OVERFILL. It is important to leave space for the salt bridge thread and a small amount of air.
5. Screw the new salt bridge into the cavity until finger tight. Now turn 1/4 turn with long nose pliers. The front face of the salt bridge should be flush with the probe face.

4.3. Replacement of Salt Bridge for Series 8 Differential Probes

1. If the system can't be calibrated after cleaning the probe, it may be necessary to replace the standard cell solution and/or the salt bridge. A salt bridge kit is available from Water Analytics for this purpose (Part No. AM60-9765K for the -8 probe and C35-17K for the -5, -6 and -7 probes). Proceed as follows: Refer to DWG N106-60.
2. Hold the probe vertically electrodes up. Remove the used salt bridge. For the -8 probe the salt bridge is a hexagonal-shaped capsule that can be removed using a 9/16" socket wrench. For the -5, -6 and -7 probes the salt bridge is a round capsule that is flush with the probe front. Use needle nose pliers to unscrew the piece.
3. Discard the used salt bridge.
4. Dispose of the used solution inside the bridge chamber and flush with pH 7 solution or distilled water.
5. Refill the chamber with 7pH buffer solution, up to the tip of the electrode, inside the chamber. DO NOT OVERFILL. It is important to leave space for the salt bridge thread and a small amount of air.
6. Screw the new salt bridge into the cavity until finger tight. Now perform a 1/4 turn with a 9/16" socket wrench. The salt bridge edges should be flush with the front of the probe face.

4.4. Storage

1. Do not discard the protective cap(s) that came with the sensor. If the sensor is removed from the process for an extended period of time, thoroughly clean the sensor, put a piece of cotton ball with few drops of water into the protective cap and replace it on the sensor. This keeps the junction from drying out which causes slow response when put back into operation or causes permanent damage to the sensor. **Sensors should not be left in dry lines or empty tanks for extended periods.**
2. Do not store the sensors in a dry or humid location. When storing, check the protective cap(s) regularly to make sure the cotton ball remains moist. Improper storage of sensors voids the warranty.

5. TROUBLESHOOTING AND SERVICE

5.1. Checking Probes P65 and R65

The operation of the 2-wire, 4-20 mA probe can be checked by a few simple measurements. For the P65 two pH buffer solutions, pH 7 and either pH 4 or pH 10, and an ammeter are required.

5.1.1. P65 pH Probes

1. Disconnect the red wire at the instrument or power supply and connect it to the milliammeter (-) black.
2. Connect the ammeter (+) red to the instrument or power supply red wire output terminal.
3. Rinse the probe and place it in 7 pH buffer. Allow the temperature of the buffer and probe to stabilize at room temperature.
4. Check the offset of the probe by reading the ammeter. The reading should be between 11 and 13 mA. If not the probe is defective. If the offset is OK, note the exact reading and proceed to the next step.
5. Rinse the probe and place it in 4 pH or 10 pH buffer. Allow the temperature of the probe and buffer to stabilize at room temperature. Now check the span of the probe by reading the ammeter. If the probe is in pH 4 buffer, the reading should be between 2.85 and 3.99 lower than the reading obtained in (d).
6. If the probe is in pH 10 buffer, the reading should be between 2.85 and 3.99 higher than the reading obtained in (d).
7. If this test is not satisfied the probe is defective.
8. If you wish to check the temperature compensator proceed to step (f).
9. If the span of the probe drops below 2.85mA than the probe still can be used adjustments will have to be made to the receiving device to compensate for the low span.
10. To check the operation of the temperature sensor in the probe, heat the buffer used in step (e) with the probe in it to about 50°C. The ammeter reading should be within ± 0.15 mA of the reading observed in step (e).

5.1.2. R65 ORP Probes

1. Disconnect the red wire at the instrument or power supply and connect it to the ammeter (-) black. Connect the ammeter (+) red to the instrument or power supply red wire output terminal.
2. For a probe with range of -500 to 500 mV (white and green wire open):
 - a. Rinse the probe and place it in the 200 mV solution. The ammeter should read between 13.7 and 16.7 mA.
 - b. Rinse the probe and place it in the 600 mV solution. The meter should read between 19.44 and 23.8 mA.
3. For a probe with range of 0 to 1000 mV: (white and green wire joined):
 - a. Rinse the probe and place it in the 200 mV solution. The ammeter should read between 6.4 and 8.0 mA.
 - b. Rinse the probe and place it in the 600 mV solution. The meter should read between 12.2 and 15.0 mA.

5.2. Troubleshooting

A pH or ORP probe is a simple instrument. As a potentiometric device it outputs a voltage in response to a change in pH or ORP. The built-in transmitter converts the voltage to a current. A probe that is not functioning properly will output a current that is out of range of the specifications listed in Section 5.1.

The change in output with calibration standard constitutes the span.

For a pH probe: The span between pH 4 and pH 7 or between pH 7 and pH 10 should be between 2.85 and 3.99 mA.

The ORP sensor is unique in that the voltage is the ORP reading. There is no span between readings of two calibration solutions. However mA readings should be within the ranges stated in Section 5.1.

If the span of a pH probe or the absolute mA readings of an ORP probe do not satisfy these criteria then the cause of the problem may be one of the following:

1. The process electrode (glass bulb) is coated with scaling or biofouling.
2. The process electrode is inoperable (likely broken).
3. The reference solution has been contaminated with the process to the point that it is no longer pH 7.
4. The salt bridge has fouled to the point that reference solution cannot pass through that is needed to complete the potentiometric circuit.
5. The printed circuit board (PCB) has shorted out by ingress or the op-amp on the board has failed.

The manifestations of these different sources are as follows:

1. A coated electrode (1) will create a narrower span or reduced ORP readings. If the coating is from scaling then soaking the probe in a weak acid (e.g. vinegar or 0.1 N HCl) will remove the scale. If the coating is from fouling then soaking the probe in bleach will clear it.
2. Either problems 2 or 5 If the pH or ORP reading does not change when changing from one calibration solution to another then either the cause is a failed PCB (5) or broken electrode (2).
3. A contaminate reference solution (3) will result in both a lower span and higher offset for pH probes or an erroneous ORP reading.
4. A fouled salt bridge (4) will result in a slower response but not necessarily a narrower span or inaccurate ORP readings. AquaMetrix sells replacement salt bridges at very modest pricing.

5.3. Customer Service

If a problem has not been resolved with the above procedures, a telephone consultation with your AquaMetrix representative, or directly with Water Analytics will provide the answer.

Water Analytics
100 School Street
Andover, MA 01810
978-749-9949
info@WaterAnalytics.net

If you are returning a probe for inspection, enclose description of the problem. Pack the probe adequately to avoid damage to the glass electrode and ensure that it will not be exposed to temperatures below -5°C . Water Analytics cannot be responsible for shipping damage nor for damage due to frozen electrodes. For safety reasons, Water Analytics cannot accept probes which have not been thoroughly cleaned to remove all process material.

5.4. Parts and Accessories

Description	Part #
Submersion Mounting Kit for Series –8 Probes	STC60L
Submersion Mounting Kit for Series –6 Probes	STC60-6
Protective shroud for Series –8 Probes	PROTECTOR-3
Protective shroud for Series –6 Probes	PROTECTOR-6
Hot/Wet tap Ball Valve Assembly for Series –7	P60-HTC
Union Mounting Tee w/ Adaptor for Series –8	AM-MH538N9A
500 mL pH 7 Buffer Solution	A35-14
4L pH 7 Buffer Solution	A35-118
500 mL pH 4 Buffer Solution	A35-13
4L pH 4 Buffer Solution	A35-117
500 mL pH 10 Buffer Solution	A35-24
4L pH 10 Buffer Solution	A35-119
500 mL 200mV Buffer Solution	A35-40
4L 200mV Buffer Solution	A35-115
500 mL 600mV Buffer Solution	A35-41
4L 600mV Buffer Solution	A35-116
Salt bridge kit for Series –4, –6, –7 & –S (Package of 3 salt bridges and cell solutions)	C35-17(K)
Salt bridge kit for Series –8 (Package of 3 salt bridges and cell solutions)	AM60-9765(K)
Junction box with terminal strip	JB-1
50 ft. 5-wire Interconnect cable dressed both ends	C42-5P-050

Probe and Accessory Photographs

P/R-65-C-8		P/R-65-C-5	
P/R-65-C-5		P/R-65-C-7	
AM-6010 AM-6040		P/R-60-C-4	
P/R-65-C-S		P/R-65-C-5-S	
Protectors -8: PROT 3 -5: PROT 5		Jet Cleaners -8: AM-JT8 -5: AM-JT5	
Salt bridge Kit		-8, -5: AM60-9765K -6: C35-17K Each kit holds 3 salt bridges and 1 vial of pH 7 Buffer solution	
Hot Tap Assembly P60-HTC		Submersion Hardware STC 60L (for -8, -5 probes)	
Union Tee AM-MH538N9A (for -8 probes)		Junction box JB-1	
pH Calibration Solutions 4: A35-17 7: A35-14 10: A35-24		ORP Calibration Solutions 200 mV: A35-40 600 mV: A35-41	

6. DRAWINGS

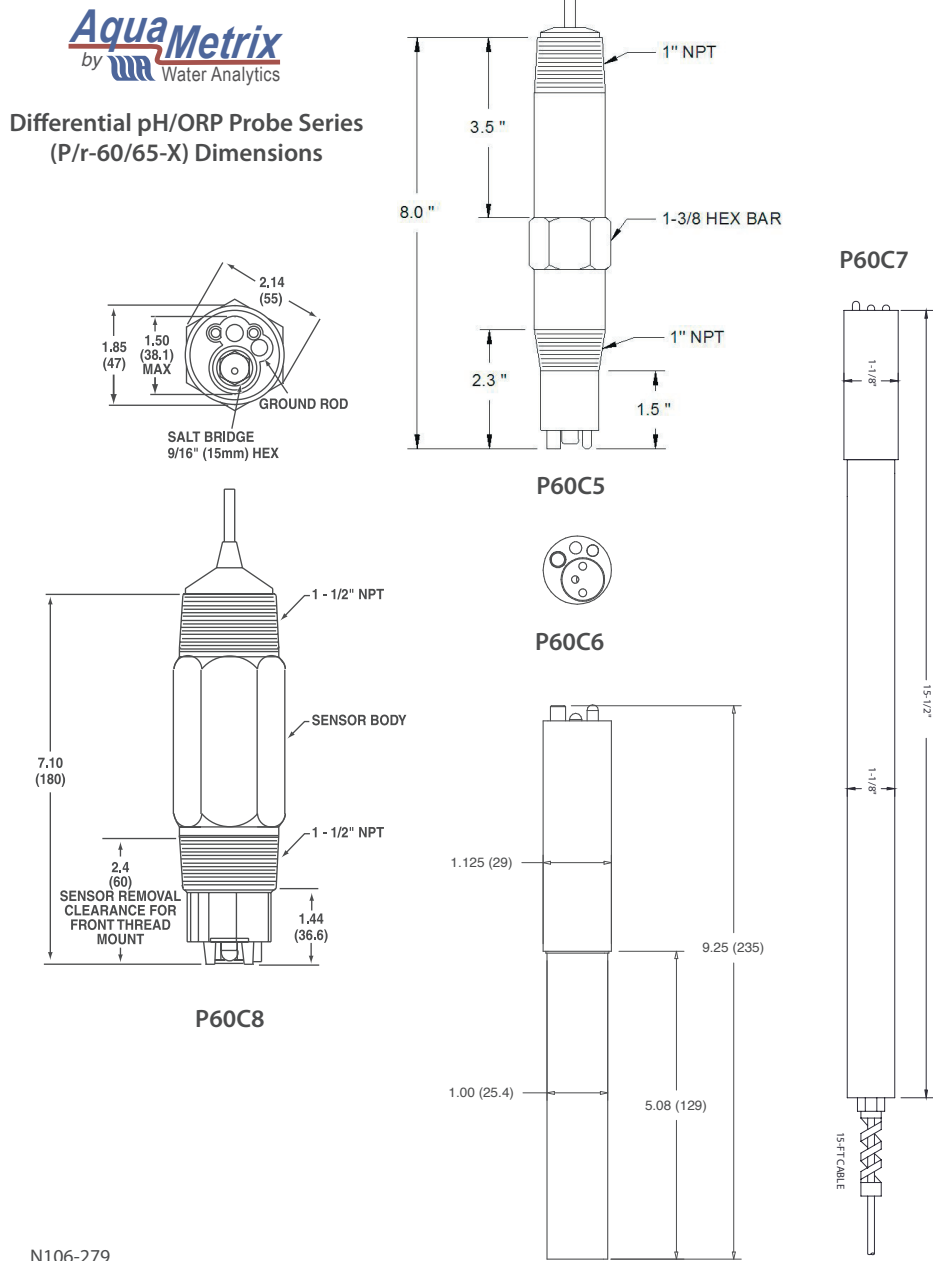
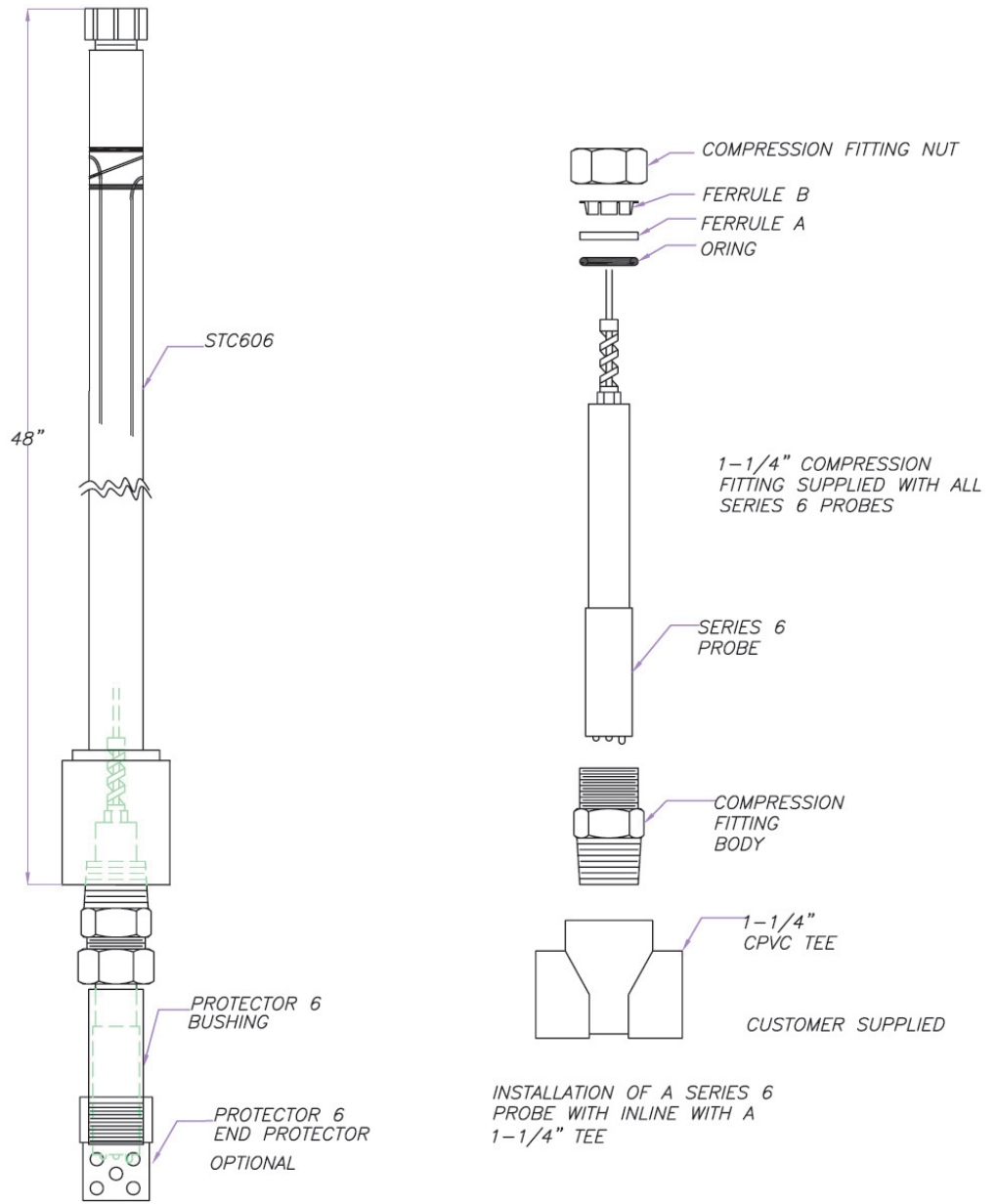

Figure 2 - Dimensions of -5, -6, -7 and -8 probes.

REVISIONS			
SYM	DESCRIPTION	DATE	APPROVAL
1	ORIGINAL ISSUE	26JAN05	P.MCLEAN



INSTALLATION OF A SERIES 6 PROBE WITH STC606 AND PROTECTOR 6 HARDWARE

<small>THE INFORMATION ON THIS DRAWING IS PROVIDED FOR CONSTRUCTION AND IS THE PROPERTY OF AQUAMETRIX INC. AND MUST NOT BE REPRODUCED OR TRANSMITTED IN ANY FORM OR BY ANY MEANS, ELECTRONIC OR MECHANICAL, INCLUDING PHOTOCOPYING, RECORDING, OR BY ANY INFORMATION STORAGE AND RETRIEVAL SYSTEM, WITHOUT THE WRITTEN PERMISSION OF THE COMPANY AND MUST NOT BE USED IN ANY MANNER UNLESS SO SPECIFIED IN THE DRAWING.</small>				BY	DATE	AquaMetrix Inc. Industrial and Environmental Controls INSTALLATION OF SERIES 6 DIFFERENTIAL PROBES	
				DESIGN	26JAN05		
	DRAWN	26JAN05	A	N105-73	1		
	APPROVED	26JAN05	SCALE: NTS	SHEET	01	OF	01

Figure 3 - Installation of a series 6 differential probe.

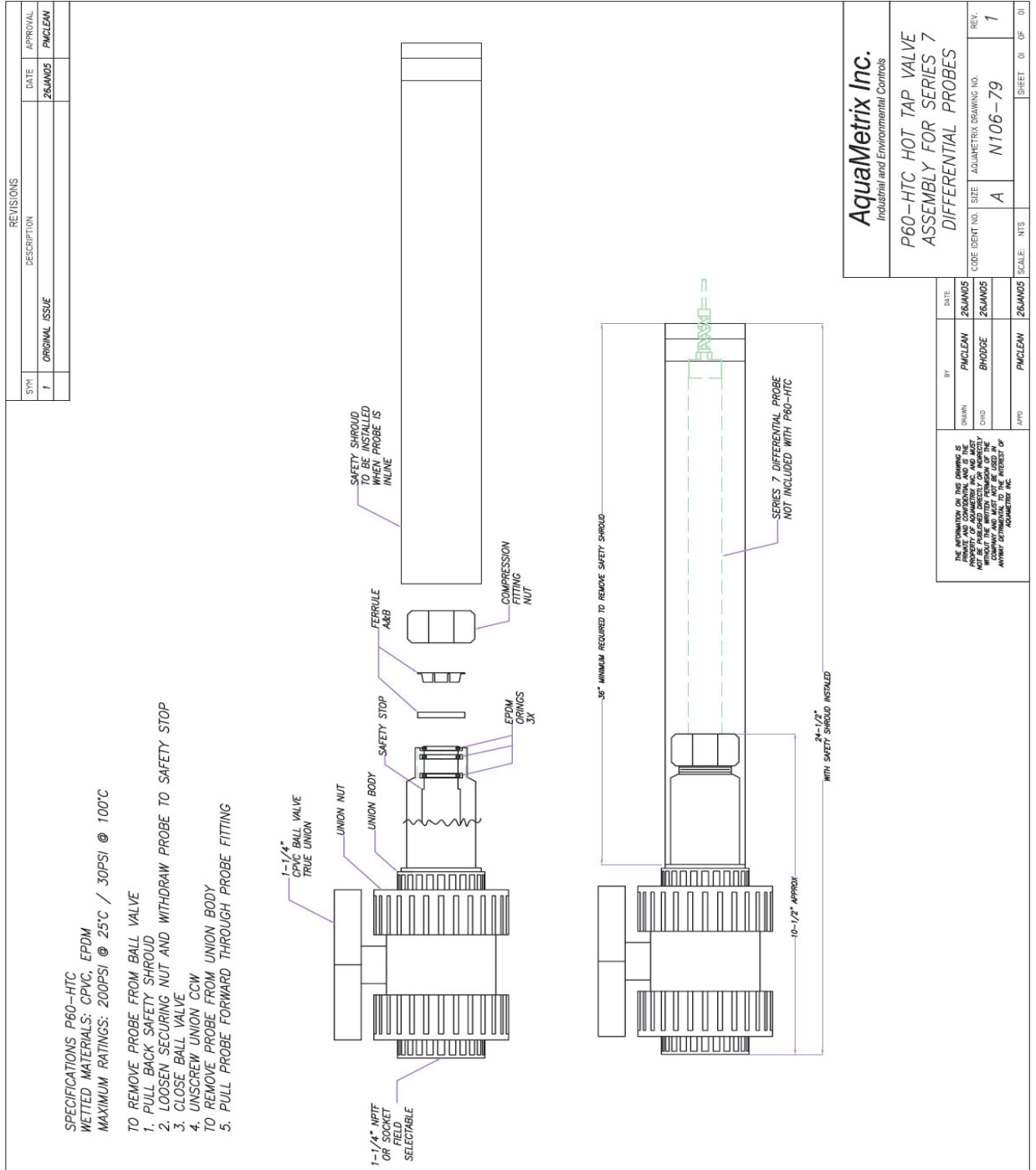

Figure 4 - Installation of a series 7 differential probe.

AquaMetrix Inc.
Industrial and Environmental Controls

P60-HTC HOT TAP VALVE ASSEMBLY FOR SERIES 7 DIFFERENTIAL PROBES

CODE IDENT NO.	A	SIZE	N106-79	REV.	1
SCALE:	NTS	SHEET:	01	OF:	01

DATE	BY	DATE	BY
26JAN05	PACLEW	26JAN05	PACLEW
	BRADDE		

THE INFORMATION ON THIS DRAWING IS PRELIMINARY AND SUBJECT TO CHANGE WITHOUT NOTICE. THE USER SHALL BE RESPONSIBLE FOR VERIFYING THE DIMENSIONS AND MATERIALS OF THE PARTS SHOWN ON THIS DRAWING. THE USER SHALL BE RESPONSIBLE FOR THE PROPER INSTALLATION AND MAINTENANCE OF THE EQUIPMENT.

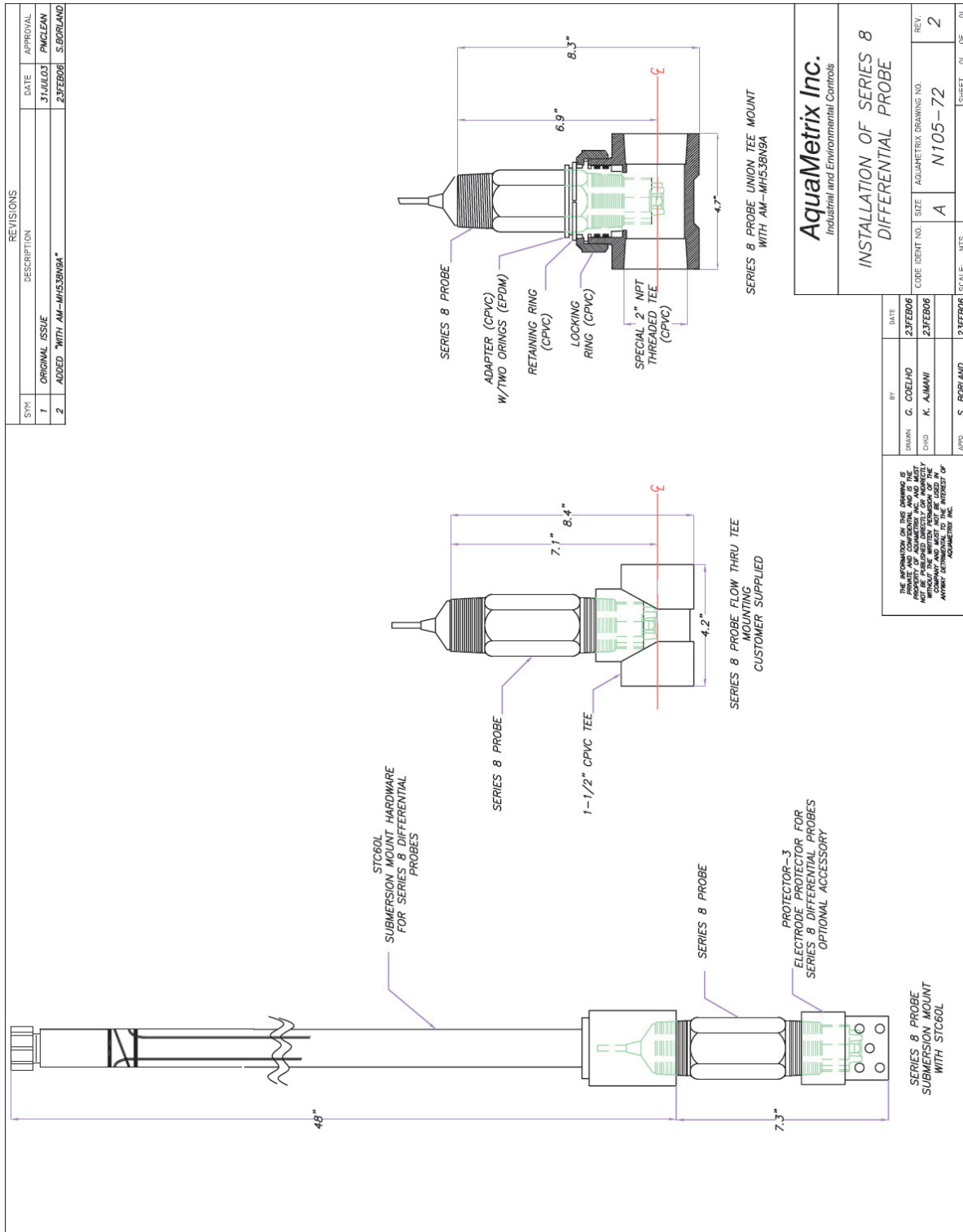

Figure 5 - Installation of a series 8 differential probe. For a series 5 probe the hardware is the same with the exception of the thread sizes of the tee, protector and submersion arm.

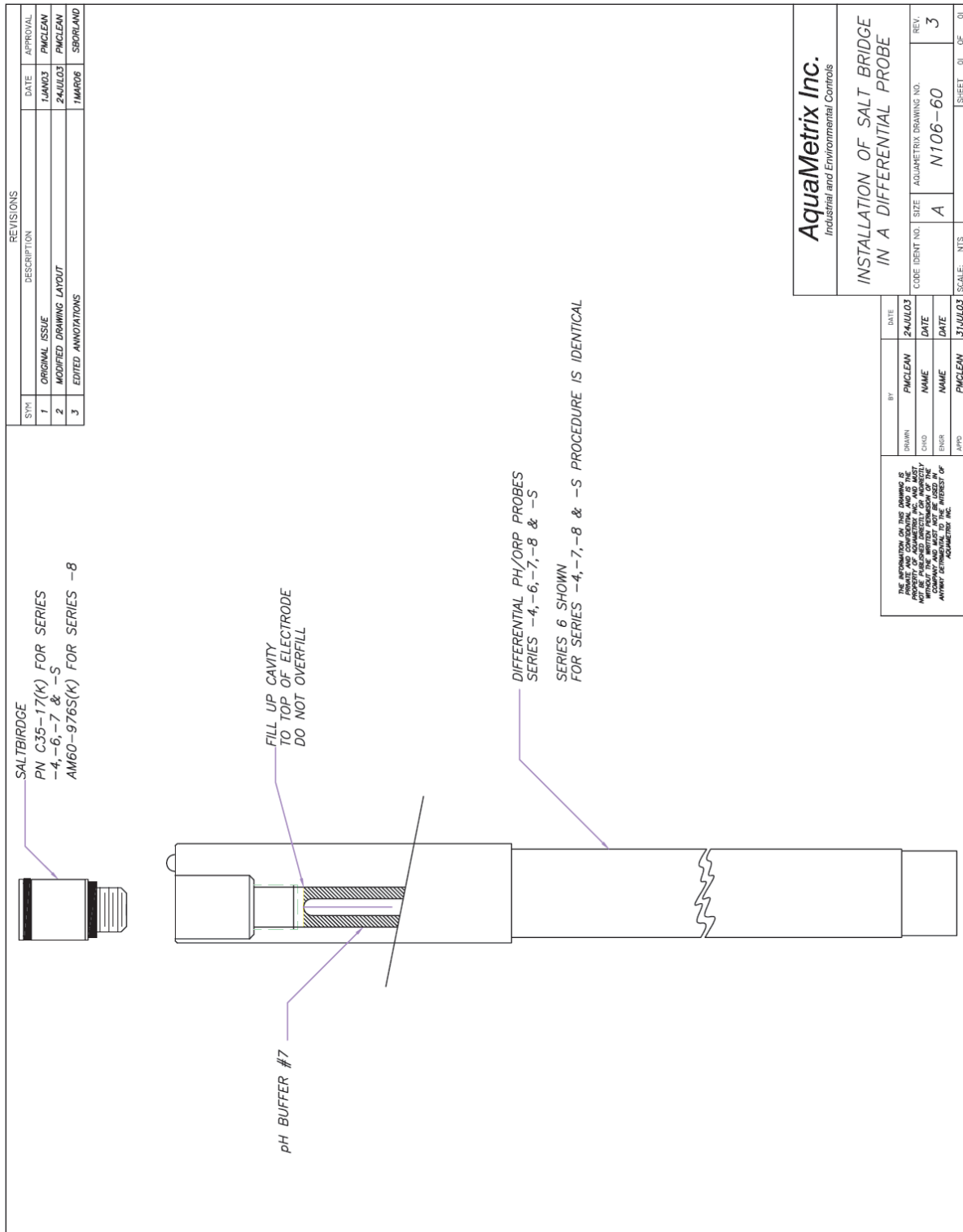

Figure 6 - Installation of salt bridge in a differential probe. The probe pictured is a series 6 or 7 probe. For a series 8 probe a hex driver is used to remove and install the salt bridge.



Water Analytics Inc.
100 School Street
Andover, MA 01810

Tel: (978) 749-9949
Toll Free: (855) PH-PROBE
www.AquaMetrix.com