

# Fit-LINE

High Purity PFA and PVDF Flare Fittings



Volume 5 FlareLINK™

## Fit-LINE PFA & PVDF flare fittings for high-purity applications and processing

Fit-LINE's PFA and PVDF FlareLINK™ tube fittings bring to the Semiconductor, Biotech, Pharmaceutical and Ultra Pure Water industries an innovative and economical way of dispensing high-purity fluids.

- **QUALITY** - Every Fit-LINE fitting is manufactured from high purity PFA and PVDF resins, providing chemical resistance and high purity. These materials are well known for use in ultra pure water and chemical applications and are Semi-F57-0301 compliant.
- **EFFICIENCY** - Our Sweep Elbows have a fully swept flow path allowing up to 300% more flow than standard elbows.
- **SIZE RANGE** - Size range is from ¼" to 1-1/4" in all the popular fitting configurations. Special fitting configurations are available on a custom basis.
- **PRECISE ASSEMBLY** - Our TruFLARE™ Tube Flaring System allows for precise and repeatable tube flares, making flare fitting assemblies easier, more cost effective and more convenient.
- **COMPATIBILITY** - Fit-LINE fittings are compatible and interchangeable with all other Fine Thread Flare Fitting systems. The fittings can be used with PFA, FEP and PTFE tubing.
- **PATENTED TightFLARE™ TECHNOLOGY** - Our proprietary technology creates repeatable and precise "Female Flare" assemblies.
- **MOLDING** - Only dedicated molds and process equipment are used for high purity production. This eliminates the possibility of cross-contamination, thus assuring "Quality without compromise."
- **HIGH PURITY** - State-of-the-art tube fittings are ideal for UPW (Ultra Pure Water) and semiconductor grade chemical applications.
- **PACKAGING** - Cleaning and packaging are proprietary processes conducted in a Class 1000 clean room using a five-stage cleaning and rinsing process. Fittings are packaged in a double polyethylene bags, ensuring the highest level of protection and contamination control.

Products listed in this catalog are protected by the following U.S. and Foreign patents:  
#5,382,151; #5,388,278; #6,164,706; #6,426,031; #7,055,870; #7,604,472 and #ZL20040019776.2.



## Table of Contents

Pressure vs Temperature Graphs .....	4	Female Run Tee .....	29
Male Connector.....	5	Female Branch Tee .....	29
Male Connector (TightFLARE™) .....	5	Flare Plug and Nut.....	30
Male Connector Panel Mount.....	6	Flare Cap .....	30
Male Connector JIS .....	6	Flare Nut PFA.....	31
Female Connector.....	7	Flare Nut PVDF.....	31
Straight Union (Male Flare x Male Flare) .....	7	Panel Mount Nut (Half Nut) PFA.....	31
Straight Union Reducer.....	8	Panel Mount Nut (Half Nut) PVDF .....	31
Straight Union (TightFLARE™) .....	8	Weld Straight Connector .....	32
Straight Union Panel Mount.....	9	Weld Straight Connector (TightFLARE™).....	32
Straight Union Panel Mount Reducer .....	9	Weld Elbow Connector .....	33
TightFLARE™ Union .....	10	Weld Elbow Connector (TightFLARE™) .....	33
TightFLARE™ Reducer .....	10	Weld Straight Reducer.....	34
TightFLARE™ Male Reducer .....	11	Weld Pipe Cap.....	34
TightFLARE™ Male Increaser .....	11	Weld Union Elbow .....	35
Double Containment Adapter.....	12	Weld Union Tee .....	35
Double Containment Fittings Panel Mount Double Containment with O-Ring Containment Seal.....	12	Weld Male Adapter .....	36
Male Elbow .....	13	Weld Female Adapter .....	36
Male Elbow (TightFLARE™) .....	13	Weld Straight Reducer (Tube x Tube).....	37
Male Elbow JIS.....	14	Weld Elbow (Tube x Tube).....	37
Female Elbow.....	14	Weld Elbow Reducer (Tube x Tube) .....	38
Union Elbow.....	15	Weld Elbow Sweep (Tube x Tube) .....	38
Union Elbow Reducer .....	15	Weld Tee (all Tube) .....	39
Union Elbow Panel Mount .....	16	Weld Tee Reducer (all Tube).....	39
Union Elbow (TightFLARE™) .....	16	Pipe Plug.....	40
Union Elbow (TightFLARE™) .....	17	Pipe Nipple .....	40
Union Elbow Reducer (TightFLARE™) .....	17	Female Male Connector Reducer .....	40
Union Elbow Sweep .....	18	Reduced Orifice Fittings.....	40
Union Elbow Sweep (TightFLARE™) .....	18	Reduced Orifice Fittings.....	40
Union Elbow Sweep (TightFLARE™) .....	19	Male Connector by Sanitary End .....	41
Male Elbow Sweep.....	19	Union Elbow by Sanitary End.....	41
Male Elbow Sweep (TightFLARE™).....	20	Multi-Flare Panel Mount .....	42
Union Tee.....	20	Multi-Flare Male Connector .....	42
Union Tee Reducer .....	21	Multi-Flare Transition Fitting .....	43
Union Tee (TightFLARE™) Branch.....	22	Transition Fitting.....	43
Union Tee (TightFLARE™) Run.....	23	TruFLARE™ Tube Flaring System Procedures.....	44
Union Tee (TightFLARE™) Branch, Run.....	24	Installation and Assembly Procedures.....	45
Union Tee (TightFLARE™) Run, Run.....	25	Recommended Nut Torque Setting.....	45
Union Tee (TightFLARE™) All .....	26	Manual Tube Flaring Tools.....	45
Male Run Tee .....	27	Welded Systems.....	46
Male Branch Tee (TightFLARE™) .....	27	Warranty .....	47
Male Branch Tee .....	28		

# Pressure vs Temperature Graphs

## PFA Fittings Pressure vs. Temperature

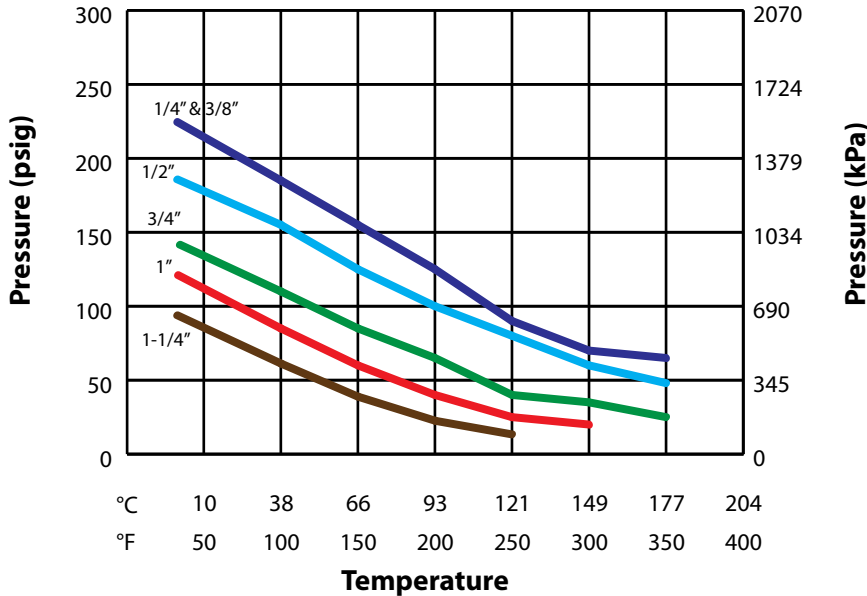

Pressure ratings for 1/4" flares are based on 0.047" wall tubing; 3/8", 1/2", 3/4" and 1" flares are based on 0.062" wall tubing and 1-1/4" flares are based on 0.075" wall tubing.

## PVDF Fittings Pressure vs. Temperature

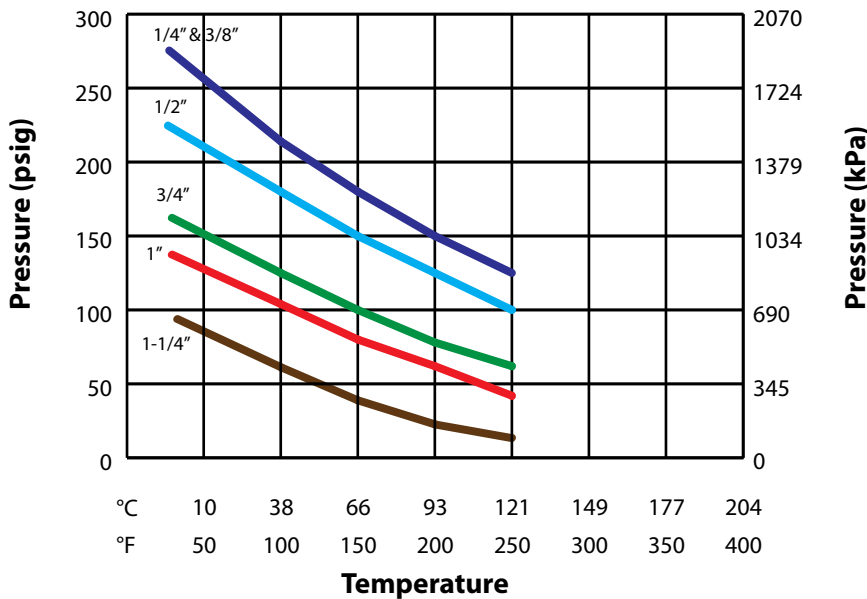

Pressure ratings for 1/4" flares are based on 0.047" wall tubing; 3/8", 1/2", 3/4" and 1" flares are based on 0.062" wall tubing and 1-1/4" flares are based on 0.075" wall tubing.

**WARNING: PVDF not for use in applications exceeding 248° F (120° C)**

Fit-LINE is not responsible for product damage due to accidents, misuse, or improper application usage.

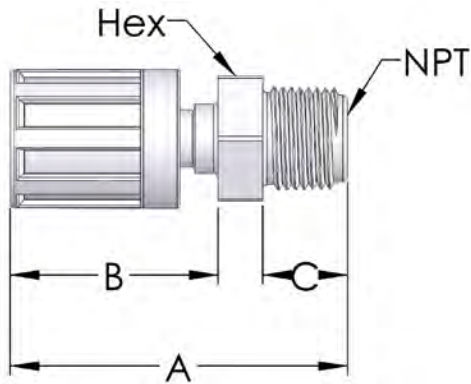
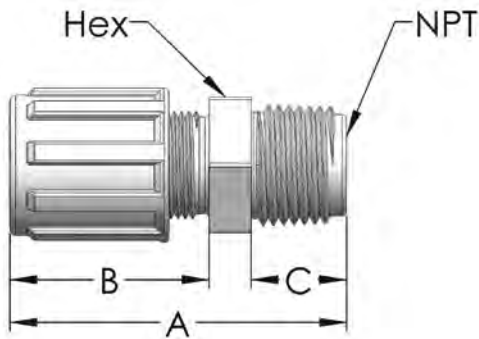

Male Connector								
PFA Part No.	PVDF Part No.	Tube O.D.	NPT Size	Orifice	A	B	C	Hex
MC4-2N-1	MC4-2	1/4	1/8	.15	1.91	1.16	.45	5/8
MC4-4N-1	MC4-4	1/4	1/4	.15	2.00	1.16	.55	5/8
MC4-6N-1	MC4-6	1/4	3/8	.15	2.00	1.16	.55	11/16
MC4-8N-1	MC4-8	1/4	1/2	.15	2.12	1.16	.66	13/16
MC4-12N-1		1/4	3/4	.15	2.12	1.16	.67	1-3/16
MC4-16N-1		1/4	1	.15	2.32	1.16	.85	1-7/16
MC6-2N-1		3/8	1/8	.18	2.09	1.27	.55	13/16
MC6-4N-1	MC6-4	3/8	1/4	.25	2.11	1.27	.55	13/16
MC6-6N-1	MC6-6	3/8	3/8	.25	2.11	1.27	.55	13/16
MC6-8N-1	MC6-8	3/8	1/2	.25	2.21	1.27	.66	15/16
MC6-12N-1	MC6-12	3/8	3/4	.25	2.22	1.27	.66	1-3/16
MC6-16N-1		3/8	1	.25	2.39	1.27	.85	1-7/16
MC8-2N-1		1/2	1/8	.18	2.20	1.36	.54	15/16
MC8-4N-1	MC8-4	1/2	1/4	.38	2.20	1.36	.55	15/16
MC8-6N-1	MC8-6	1/2	3/8	.38	2.20	1.36	.55	15/16
MC8-8N-1	MC8-8	1/2	1/2	.38	2.32	1.36	.66	15/16
MC8-12N-1	MC8-12	1/2	3/4	.38	2.32	1.36	.66	1-3/16
MC8-16N-1		1/2	1	.38	2.51	1.36	.86	1-7/16
MC12-6N-1		3/4	3/8	.38	2.37	1.52	.56	15/16
MC12-8N-1	MC12-8	3/4	1/2	.51	2.48	1.52	.67	1-3/16
MC12-12N-1	MC12-12	3/4	3/4	.63	2.48	1.52	.67	1-3/16
MC12-16N-1	MC12-16	3/4	1	.63	2.66	1.52	.85	1-7/16
MC16-8N-1		1	1/2	.51	2.69	1.73	.67	1-7/16
MC16-12N-1	MC16-12	1	3/4	.66	2.69	1.73	.67	1-7/16
MC16-16N-1	MC16-16	1	1	.88	2.88	1.73	.86	1-7/16
MC20-16N-1		1-1/4	1	.97	3.29	2.06	.86	1-3/4
MC20-20N-1		1-1/4	1-1/4	1.10	3.29	2.06	.86	1-3/4

Male Connector (TightFLARE™)							
(Female Flare x NPT)							
U.S. Patent 7,055,870							
PFA Part No.	TightFLARE™	NPT Size	Orifice	A	B	C	Hex
MC4T-2N-1	1/4	1/8	.15	2.16	1.31	.45	5/8
MC4T-4N-1	1/4	1/4	.15	2.13	1.29	.55	5/8
MC4T-6N-1	1/4	3/8	.15	2.13	1.29	.55	11/16
MC4T-8N-1	1/4	1/2	.15	2.27	1.31	.67	13/16
MC6T-4N-1	3/8	1/4	.25	2.22	1.37	.56	13/16
MC6T-6N-1	3/8	3/8	.25	2.22	1.37	.55	13/16
MC6T-8N-1	3/8	1/2	.25	2.33	1.37	.67	13/16
MC8T-4N-1	1/2	1/4	.25	2.28	1.43	.56	15/16
MC8T-6N-1	1/2	3/8	.38	2.26	1.42	.55	13/16
MC8T-8N-1	1/2	1/2	.38	2.47	1.51	.67	15/16
MC12T-8N-1	3/4	1/2	.51	2.57	1.61	.67	1-3/16
MC12T-12N-1	3/4	3/4	.63	2.57	1.61	.67	1-3/16
MC12T-16N-1	3/4	1	.63	2.76	1.61	.86	1-7/16
MC16T-16N-1	1	1	.88	2.99	1.84	.86	1-7/16

Male Connector Panel Mount											
PFA Part No.	PVDF Part No.	Tube O.D.	NPT Size	Orifice	A	B	C	D (Max)	Hex 1	Hex 2	Minimum Panel Hole Diameter
MCPM4-2N-1	MCPM4-2	1/4	1/8	.15	2.78	1.94	.55	.50	3/4	11/16	1/2
MCPM4-4N-1	MCPM4-4	1/4	1/4	.15	2.78	1.94	.55	.50	3/4	11/16	1/2
MCPM4-6N-1		1/4	3/8	.15	2.78	1.94	.55	.50	3/4	11/16	1/2
MCPM6-4N-1		3/8	1/4	.25	2.87	2.03	.55	.50	15/16	13/16	5/8
MCPM6-6N-1	MCPM6-6	3/8	3/8	.25	2.87	2.03	.55	.50	15/16	13/16	5/8
MCPM8-4N-1		1/2	1/4	.38	2.99	2.14	.55	.50	1-1/16	15/16	3/4
MCPM8-6N-1		1/2	3/8	.38	2.99	2.14	.55	.50	1-1/16	15/16	3/4
MCPM8-8N-1	MCPM8-8	1/2	1/2	.38	3.10	2.14	.67	.50	1-1/16	15/16	3/4
MCPM12-12N-1	MCPM12-12	3/4	3/4	.63	3.26	2.29	.68	.50	1-5/16	1-3/16	1
MCPM16-16N-1	MCPM16-16	1	1	.88	3.66	2.51	.86	.50	1-3/4	1-5/8	1-7/16

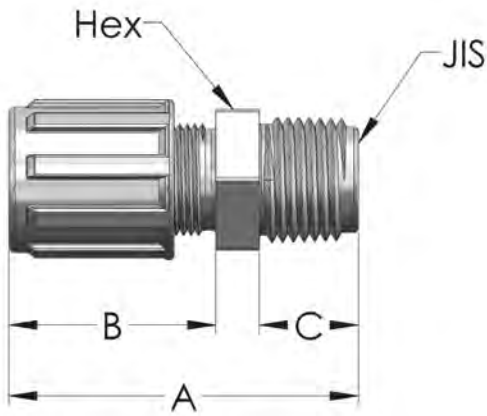
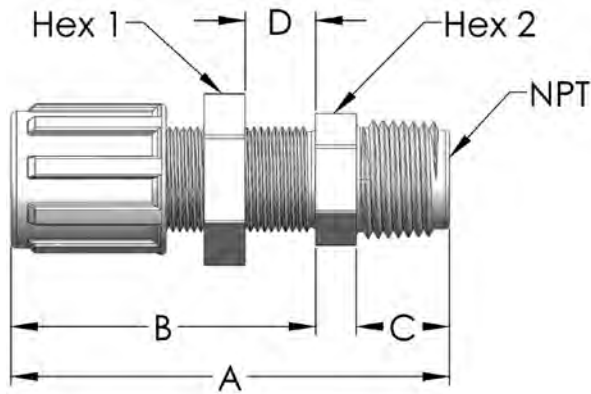

Male Connector JIS							
PFA Part No.	Tube O.D.	JIS Size	Orifice	A	B	C	Hex
MC4-4JN-1	1/4	1/4	.15	2.00	1.16	.56	5/8
MC4-6JN-1	1/4	3/8	.15	2.00	1.16	.56	11/16
MC4-8JN-1	1/4	1/2	.15	2.11	1.16	.66	15/16
MC6-4JN-1	3/8	1/4	.25	2.11	1.26	.56	13/16
MC6-6JN-1	3/8	3/8	.25	2.11	1.26	.56	13/16
MC6-8JN-1	3/8	1/2	.25	2.22	1.26	.67	15/16
MC8-4JN-1	1/2	1/4	.38	2.20	1.36	.56	15/16
MC8-6JN-1	1/2	3/8	.38	2.20	1.36	.56	15/16
MC8-8JN-1	1/2	1/2	.38	2.32	1.36	.67	15/16
MC8-12JN-1	1/2	3/4	.38	2.32	1.36	.68	1-3/16
MC12-6JN-1	3/4	3/8	.63	2.37	1.52	.56	1-3/16
MC12-8JN-1	3/4	1/2	.51	2.48	1.52	.67	1-3/16
MC12-12JN-1	3/4	3/4	.63	2.49	1.52	.67	1-3/16
MC12-16JN-1	3/4	1	.63	2.65	1.52	.85	1-7/16
MC16-12JN-1	1	3/4	.66	2.69	1.73	.67	1-7/16
MC16-16JN-1	1	1	.88	2.87	1.73	.85	1-7/16

Female Connector								
PFA Part No.	PVDF Part No.	Tube O.D.	NPT Size	Orifice	A	B	C	Hex
FC4-2N-1	FC4-2	1/4	1/8	.15	1.90	1.16	.49	5/8
FC4-4N-1	FC4-4	1/4	1/4	.15	1.99	1.16	.54	3/4
FC4-6N-1	FC4-6	1/4	3/8	.15	2.00	1.16	.55	15/16
FC4-8N-1		1/4	1/2	.15	2.02	1.16	.57	1-1/8
FC6-4N-1	FC6-4	3/8	1/4	.25	2.08	1.27	.54	3/4
FC6-6N-1	FC6-6	3/8	3/8	.25	2.10	1.27	.55	15/16
FC6-8N-1	FC6-8	3/8	1/2	.25	2.13	1.27	.57	1-1/8
FC8-4N-1		1/2	1/4	.38	2.18	1.36	.54	3/4
FC8-6N-1	FC8-6	1/2	3/8	.38	2.20	1.36	.55	15/16
FC8-8N-1	FC8-8	1/2	1/2	.38	2.22	1.36	.57	1-1/8
FC8-12N-1	FC8-12	1/2	3/4	.38	2.28	1.36	.63	1-3/8
FC8-16N-1		1/2	1	.38	2.50	1.36	.85	1-5/8
FC12-8N-1	FC12-8	3/4	1/2	.63	2.38	1.52	.57	1-1/8
FC12-12N-1	FC12-12	3/4	3/4	.63	2.44	1.52	.63	1-3/8
FC12-16N-1		3/4	1	.63	2.66	1.52	.85	1-5/8
FC16-16N-1	FC16-16	1	1	.88	2.88	1.74	.85	1-5/8

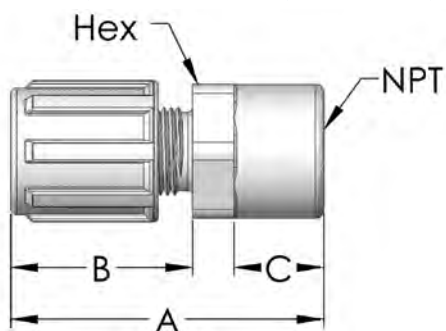

Straight Union (Male Flare x Male Flare)						
PFA Part No.	PVDF Part No.	Tube O.D.	Orifice	A	B	Hex
SU44N-1	SU44	1/4	.15	2.62	1.16	11/16
SU66N-1	SU66	3/8	.25	2.83	1.27	13/16
SU88N-1	SU88	1/2	.38	3.02	1.36	15/16
SU1212N-1	SU1212	3/4	.63	3.32	1.52	1-3/16
SU1616N-1	SU1616	1	.88	3.72	1.73	1-7/16
SU2020N-1		1-1/4	1.10	4.88	2.25	1-3/4

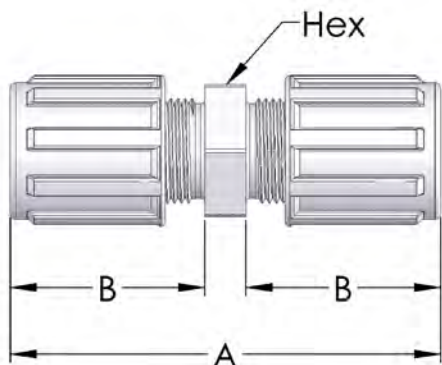



Straight Union Reducer								
PFA Part No.	PVDF Part No.	Tube O.D.	Tube O.D.	Orifice	A	B	C	Hex
SU64N-1	SU64	3/8	1/4	.15	2.72	1.27	1.16	11/16
SU84N-1		1/2	1/4	.15	2.82	1.36	1.16	15/16
SU86N-1	SU86	1/2	3/8	.25	2.92	1.36	1.27	15/16
SU124N-1		3/4	1/4	.15	2.96	1.52	1.16	1-3/16
SU126N-1		3/4	3/8	.25	3.07	1.52	1.27	1-3/16
SU128N-1	SU128	3/4	1/2	.38	3.17	1.52	1.36	1-3/16
SU168N-1		1	1/2	.38	3.38	1.73	1.36	1-7/16
SU1612N-1	SU1612	1	3/4	.66	3.53	1.73	1.52	1-7/16
SU2016N-1		1-1/4	1	.88	4.36	2.25	1.73	1-3/4

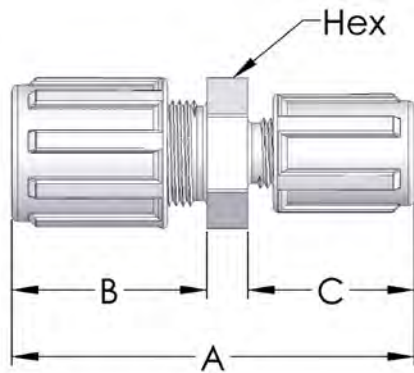

Straight Union (TightFLARE™) (Male Flare x Female Flare) U.S. Patent 7,055,870					
PFA Part No.	Tube O.D. / TightFLARE™	Orifice	A	B	Hex
SU44TN-1	1/4	.15	2.76	1.16	11/16
SU66TN-1	3/8	.25	2.93	1.27	13/16
SU88TN-1	1/2	.38	3.07	1.36	15/16
SU1212TN-1	3/4	.63	3.41	1.52	1-3/16
SU1616TN-1	1	.88	4.04	1.73	1-7/16

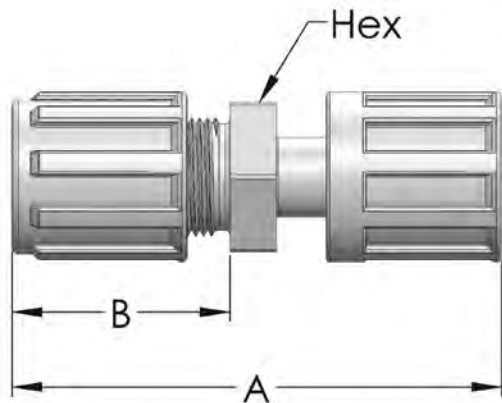



Straight Union Panel Mount										
PFA Part No.	PVDF Part No.	Tube O.D.	Orifice	A	B	C	D (Max)	Hex 1	Hex2	Minimum Panel Hole Diameter
SPM44N-1	SPM44	1/4	.15	3.40	1.94	1.16	.50	3/4	11/16	1/2
SPM66N-1	SPM66	3/8	.25	3.58	2.02	1.27	.50	15/16	13/16	5/8
SPM88N-1	SPM88	1/2	.38	3.80	2.24	1.36	.50	1-1/16	15/16	3/4
SPM1212N-1	SPM1212	3/4	.63	4.11	2.30	1.52	.50	1-5/16	1-3/16	1
SPM1616N-1	SPM1616	1	.88	4.53	2.52	1.73	.50	1-3/4	1-5/8	1-7/16

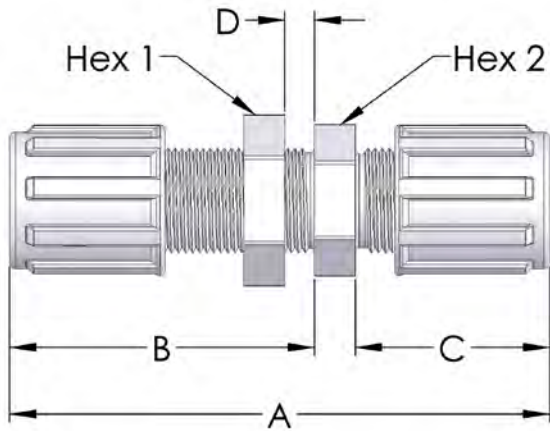

Straight Union Panel Mount Reducer											
PFA Part No.	PVDF Part No.	Tube O.D.	Tube O.D.	Orifice	A	B	C	D (Max)	Hex 1	Hex2	Minimum Panel Hole Diameter
SPM64N-1	SPM64	3/8	1/4	.15	3.48	2.03	1.16	.50	15/16	13/16	5/8
SPM84N-1		1/2	1/4	.15	3.59	2.14	1.16	.50	1-1/16	15/16	3/4
SPM86N-1	SPM86	1/2	3/8	.25	3.70	2.14	1.27	.50	1-1/16	15/16	3/4
SPM126N-1		3/4	3/8	.25	3.86	2.30	1.27	.50	1-5/16	1-3/16	1
SPM128N-1	SPM128	3/4	1/2	.38	3.95	2.30	1.36	.50	1-5/16	1-3/16	1
SPM1612N-1		1	3/4	.63	4.31	2.50	1.52	.50	1-3/4	1-5/8	1-7/16

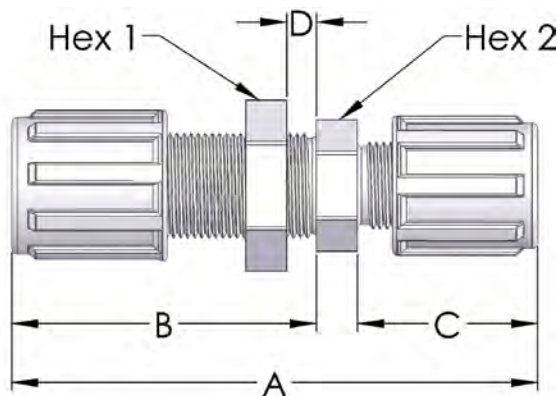

TightFLARE™ Union (Female Flare x Female Flare) U.S. Patent 7,055,870						
PFA Part No.	TightFLARE™	Orifice	A	B	C	D
TFU4N-1	1/4	.15	2.40	1.03	.36	.78
TFU6N-1	3/8	.25	2.58	1.10	.38	.91
TFU8N-1	1/2	.38	2.69	1.15	.38	1.03
TFU12N-1	3/4	.63	3.00	1.32	.38	1.35
TFU16N-1	1	.88	3.52	1.50	.52	1.76
TFU20N-1	1-1/4	1.10	4.18	1.83	.52	2.20

CUSTOM "A" DIMENSIONS AVAILABLE UPON REQUEST.

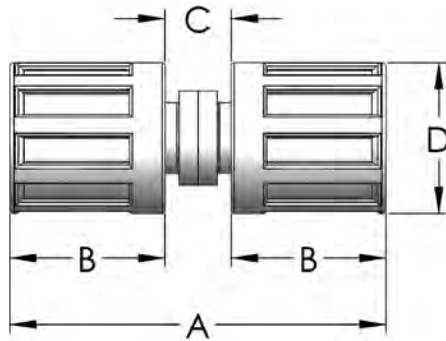

TightFLARE™ Female Reducer (Female Flare x Female Flare) U.S. Patent 7,055,870				
PFA Part No.	TightFLARE™ 1	TightFLARE™ 2	Orifice	A
TFFR64N-1	3/8	1/4	.15	.29
TFFR84N-1	1/2	1/4	.15	.41
TFFR86N-1	1/2	3/8	.25	.29
TFFR124N-1	3/4	1/4	.15	.41
TFFR126N-1	3/4	3/8	.25	.41
TFFR128N-1	3/4	1/2	.38	.41
TFFR164N-1	1	1/4	.15	.34
TFFR166N-1	1	3/8	.25	.34
TFFR168N-1	1	1/2	.38	.35
TFFR1612N-1	1	3/4	.63	.35

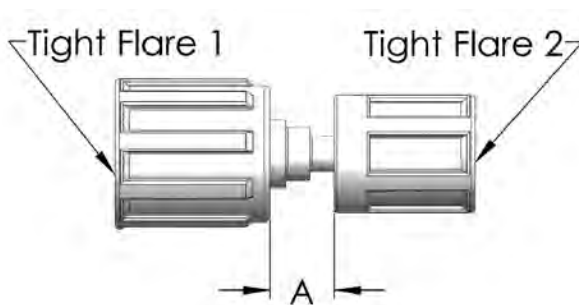

### TightFLARE™ Male Reducer

(Female Flare x Male)

U.S. Patent 7,055,870

PFA Part No.	TightFLARE™	Tube O.D.	Orifice	A
TFMR64N-1	3/8	1/4	.15	1.33
TFMR84N-1	1/2	1/4	.15	1.27
TFMR86N-1	1/2	3/8	.25	1.42
TFMR124N-1	3/4	1/4	.15	1.27
TFMR126N-1	3/4	3/8	.25	1.37
TFMR128N-1	3/4	1/2	.38	1.47
TFMR164N-1	1	1/4	.15	1.23
TFMR166N-1	1	3/8	.25	1.32
TFMR168N-1	1	1/2	.38	1.43
TFMR1612N-1	1	3/4	.63	1.56
TFMR204N-1	1-1/4	1/4	.15	1.27
TFMR206N-1	1-1/4	3/8	.25	1.37
TFMR208N-1	1-1/4	1/2	.38	1.47
TFMR2012N-1	1-1/4	3/4	.63	1.56
TFMR2016N-1	1-1/4	1	.88	2.02

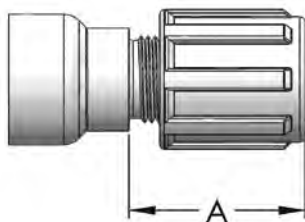

### TightFLARE™ Male Increaser

(Female Flare x Male)

U.S. Patent 7,055,870

PFA Part No.	TightFLARE™	Tube O.D.	Orifice	A	B	Hex
TFMI46N-1	1/4	3/8	.15	2.88	1.33	13/16
TFMI48N-1	1/4	1/2	.15	2.97	1.33	15/16
TFMI68N-1	3/8	1/2	.25	3.03	1.38	15/16
TFMI612N-1	3/8	3/4	.25	3.19	1.38	1-3/16
TFMI812N-1	1/2	3/4	.38	3.23	1.42	1-3/16
TFMI816N-1	1/2	1	.38	3.44	1.42	1-7/16
TFMI1216N-1	3/4	1	.63	3.66	1.60	1-7/16
TFMI1620N-1	1	1-1/4	.88	4.39	1.76	1-3/4

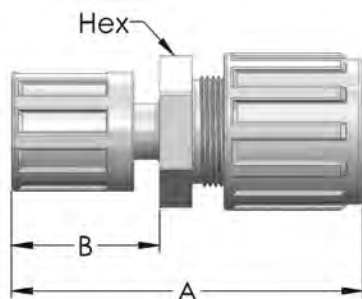

Double Containment Adapter					
PVDF Part No.	Primary O.D.	Containment O.D.	A	B	Hex
DC48	1/4	1/2	1.40	1.03	15/16
DC612	3/8	3/4	1.78	1.35	1-3/16
DC812	1/2	3/4	1.78	1.35	1-3/16
DC1216	3/4	1	2.04	1.82	1-9/16

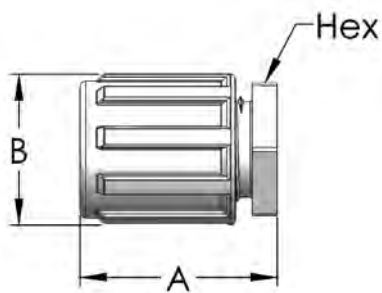

Double Containment Fittings Panel Mount Double Containment with O-Ring Containment Seal										
PFA Part No.	Primary O.D.	Containment O.D.	Orifice	A	B	C	D	Hex 1	Hex 2	Minimum Panel Hole Diameter
PM44DC8N-1	1/4	1/2	.15	3.60	1.53	2.07	.25	3/4	11/16	1/2
PM66DC12N-1	3/8	3/4	.25	3.95	1.63	2.32	.25	1-5/16	13/16	5/8
PM88DC12N-1	1/2	3/4	.38	4.15	1.73	2.42	.25	1-1/16	15/16	3/4
PM1212DC16N-1	3/4	1	.63	4.58	1.88	2.70	.25	1-5/16	1-3/16	1

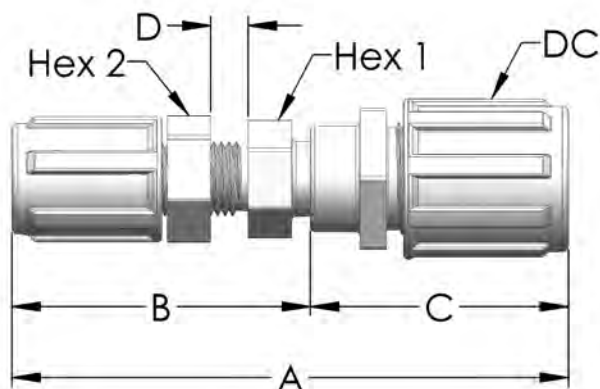



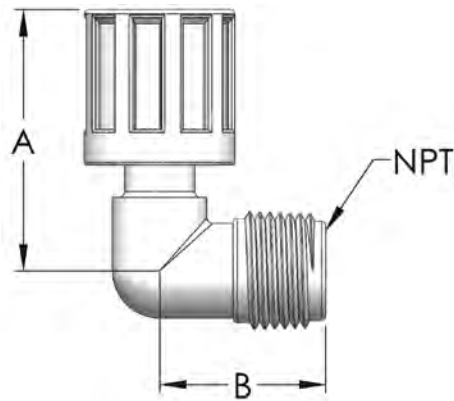
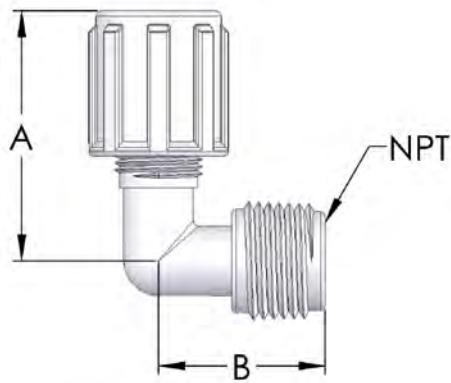

**Male Elbow**

PFA Part No.	PVDF Part No.	Tube O.D.	NPT Size	Orifice	A	B
ME4-2N-1	ME4-2	1/4	1/8	.15	1.66	1.06
ME4-4N-1	ME4-4	1/4	1/4	.15	1.66	1.06
ME4-6N-1	ME4-6	1/4	3/8	.15	1.66	1.06
ME4-8N-1		1/4	1/2	.15	1.66	1.17
ME6-2N-1		3/8	1/8	.18	1.76	1.06
ME6-4N-1	ME6-4	3/8	1/4	.25	1.76	1.06
ME6-6N-1	ME6-6	3/8	3/8	.25	1.76	1.06
ME6-8N-1	ME6-8	3/8	1/2	.25	1.76	1.18
ME6-12N-1		3/8	3/4	.25	1.76	1.36
ME8-2N-1		1/2	1/8	.18	1.86	1.06
ME8-4N-1		1/2	1/4	.25	1.86	1.06
ME8-6N-1	ME8-6	1/2	3/8	.38	1.86	1.06
ME8-8N-1	ME8-8	1/2	1/2	.38	1.86	1.18
ME8-12N-1	ME8-12	1/2	3/4	.49	1.86	1.36
ME8-16N-1		1/2	1	.38	1.86	1.80
ME12-6N-1		3/4	3/8	.36	2.21	1.23
ME12-8N-1	ME12-8	3/4	1/2	.53	2.21	1.36
ME12-12N-1	ME12-12	3/4	3/4	.63	2.21	1.37
ME12-16N-1	ME12-16	3/4	1	.63	2.21	1.80
ME16-8N-1		1	1/2	.51	2.70	1.37
ME16-12N-1	ME16-12	1	3/4	.66	2.70	1.64
ME16-16N-1	ME16-16	1	1	.87	2.70	1.80

**Male Elbow (TightFLARE™)**

U.S. Patent 7,055,870

PFA Part No.	TightFLARE™ Size	NPT Size	Orifice	A	B
ME4T-4N-1	1/4	1/4	.15	1.66	1.06
ME6T-6N-1	3/8	3/8	.25	1.76	1.06
ME8T-8N-1	1/2	1/2	.38	1.85	1.18
ME12T-12N-1	3/4	3/4	.63	1.76	1.36
ME16T-16N-1	1	1	.88	1.76	1.18

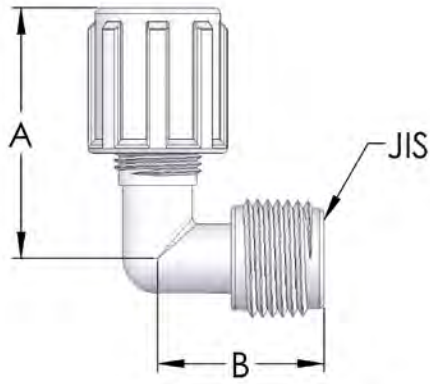

Male Elbow JIS					
PFA Part No.	Tube O.D.	JIS Size	Orifice	A	B
ME4-4JN-1	1/4	1/4	.15	1.66	1.06
ME4-6JN-1	1/4	3/8	.15	1.66	1.06
ME6-4JN-1	3/8	1/4	.25	1.76	1.06
ME6-6JN-1	3/8	3/8	.25	1.76	1.06
ME6-8JN-1	3/8	1/2	.25	1.76	1.18
ME8-4JN-1	1/2	1/4	.25	1.86	1.06
ME8-6JN-1	1/2	3/8	.38	1.86	1.06
ME8-8JN-1	1/2	1/2	.38	1.86	1.18
ME8-12JN-1	1/2	3/4	.38	1.86	1.36
ME12-8JN-1	3/4	1/2	.53	2.21	1.36
ME12-12JN-1	3/4	3/4	.63	2.21	1.37
ME12-16JN-1	3/4	1	.63	2.21	1.80
ME16-12JN-1	1	3/4	.66	2.70	1.64
ME16-16JN-1	1	1	.87	2.70	1.80

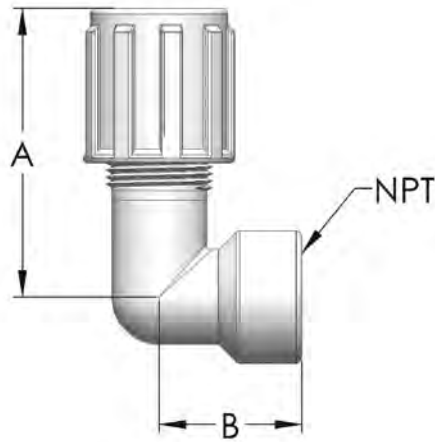

Female Elbow						
PFA Part No.	PVDF Part No.	Tube O.D.	NPT Size	Orifice	A	B
FE4-2N-1	FE4-2	1/4	1/8	.15	1.80	.81
FE4-4N-1	FE4-4	1/4	1/4	.15	1.80	.94
FE4-6N-1	FE4-6	1/4	3/8	.15	1.80	1.00
FE4-8N-1		1/4	1/2	.15	1.80	1.25
FE6-4N-1	FE6-4	3/8	1/4	.25	1.91	.94
FE6-6N-1	FE6-6	3/8	3/8	.25	1.91	1.00
FE6-8N-1	FE6-8	3/8	1/2	.25	1.91	1.25
FE8-4N-1		1/2	1/4	.36	2.03	.96
FE8-6N-1	FE8-6	1/2	3/8	.38	2.03	1.00
FE8-8N-1	FE8-8	1/2	1/2	.38	2.03	1.27
FE8-12N-1		1/2	3/4	.38	2.03	1.53
FE12-8N-1		3/4	1/2	.54	2.22	1.44
FE12-12N-1		3/4	3/4	.63	2.22	1.53
FE16-16N-1		1	1	.88	2.67	1.60

Union Elbow					
PFA Part No.	PVDF Part No.	Tube	Orifice	A	B
UE44N-1	UE44	1/4	.15	1.66	1.66
UE66N-1	UE66	3/8	.25	1.76	1.76
UE88N-1	UE88	1/2	.38	1.87	1.87
UE1212N-1	UE1212	3/4	.63	2.22	2.22
UE1616N-1	UE1616	1	.87	2.70	2.70
UE2020N-1		1-1/4	1.10	2.96	2.96

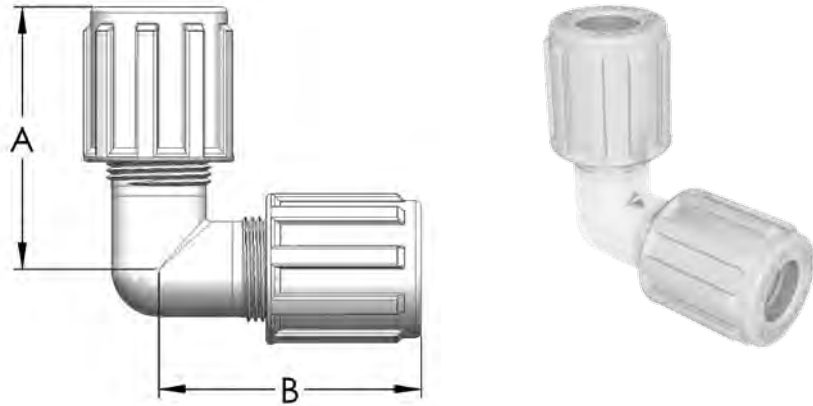

Union Elbow Reducer						
PFA Part No.	PVDF Part No.	Tube O.D.	Tube O.D.	Orifice	A	B
UE64N-1	UE64	3/8	1/4	.15	1.76	1.66
UE84N-1	UE84	1/2	1/4	.15	1.87	1.66
UE86N-1	UE86	1/2	3/8	.25	1.87	1.76
UE124N-1		3/4	1/4	.15	2.22	1.66
UE126N-1		3/4	3/8	.25	2.22	1.76
UE128N-1	UE128	3/4	1/2	.38	2.22	1.87
UE168N-1		1	1/2	.38	2.70	2.03
UE1612N-1	UE1612	1	3/4	.63	2.70	2.22

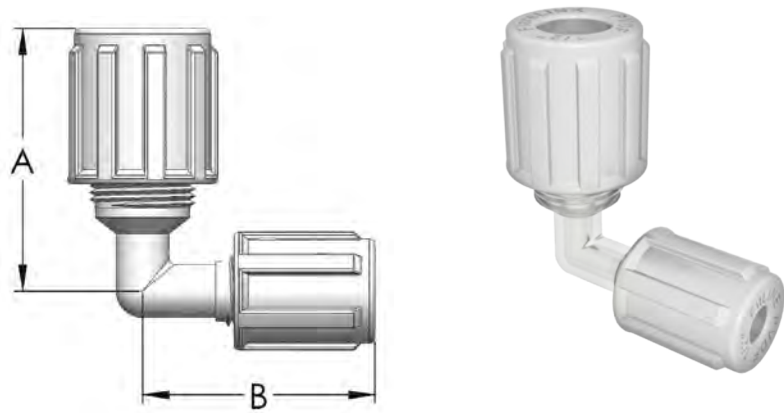

Union Elbow Panel Mount							
PFA Part No.	Tube O.D.	Orifice	A	B	C	D (Max)	Minimum Panel Hole Diameter
EPMX44N-1	1/4	.15	1.66	1.85	.51	.50	1/2
EPMX66N-1	3/8	.25	1.77	1.96	.51	.50	5/8
EPMX88N-1	1/2	.38	1.88	1.94	.66	.50	3/4
EPMX1212N-1	3/4	.63	2.21	2.21	.84	.50	1

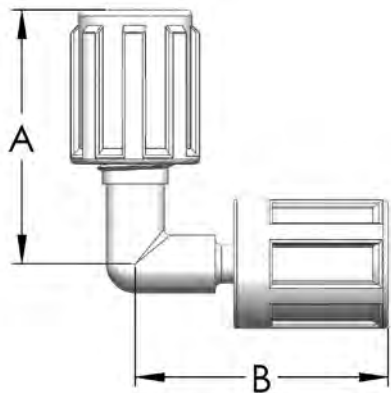
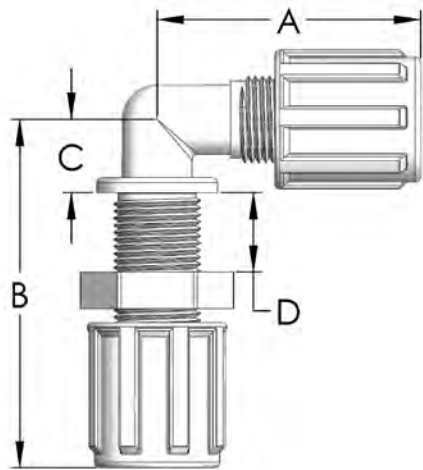

Union Elbow (TightFLARE™) (Male x Female Flare) U.S. Patent 7,055,870					
PFA Part No.	Tube O.D.	TightFLARE™	Orifice	A	B
UE44TN-1	1/4	1/4	.15	1.65	1.64
UE46TN-1	1/4	3/8	.15	1.65	1.73
UE48TN-1	1/4	1/2	.15	1.65	1.84
UE64TN-1	3/8	1/4	.15	1.76	1.64
UE66TN-1	3/8	3/8	.25	1.76	1.73
UE68TN-1	3/8	1/2	.25	1.76	1.84
UE612TN-1	3/8	3/4	.25	1.76	2.13
UE84TN-1	1/2	1/4	.15	1.87	1.64
UE86TN-1	1/2	3/8	.25	1.87	1.73
UE88TN-1	1/2	1/2	.38	1.87	1.84
UE812TN-1	1/2	3/4	.38	1.87	2.13
UE816TN-1	1/2	1	.38	2.03	2.74
UE126TN-1	3/4	3/8	.25	2.22	1.73
UE128TN-1	3/4	1/2	.38	2.22	1.84
UE1212TN-1	3/4	3/4	.63	2.22	2.13
UE1216TN-1	3/4	1	.63	2.22	2.74
UE1612TN-1	1	3/4	.63	2.70	2.13
UE1616TN-1	1	1	.88	2.70	2.74
UE2020TN-1	1-1/4	1-1/4	1.10	2.96	3.10





### Union Elbow (TightFLARE™)

(Female Flare x Female Flare)

U.S. Patent 7,055,870

PFA Part No.	TightFLARE™	Orifice	A	B
UE4TN-1	1/4	.15	1.64	1.64
UE6TN-1	3/8	.25	1.73	1.73
UE8TN-1	1/2	.38	1.84	1.84
UE12TN-1	3/4	.63	2.13	2.13
UE16TN-1	1	.88	2.74	2.74
UE20TN-1	1-1/4	1.10	3.10	3.10

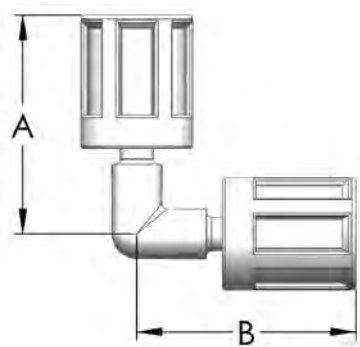

### Union Elbow Reducer (TightFLARE™)

(Female Flare x Female Flare)

U.S. Patent 7,055,870

PFA Part No.	TightFLARE™	TightFLARE™	Orifice	A	B
UE6T4TN-1	3/8	1/4	.15	1.73	1.64
UE8T4TN-1	1/2	1/4	.15	1.84	1.64
UE8T6TN-1	1/2	3/8	.25	1.84	1.73
UE12T8TN-1	3/4	1/2	.38	2.13	1.84
UE16T12TN-1	1	3/4	.63	2.74	2.13

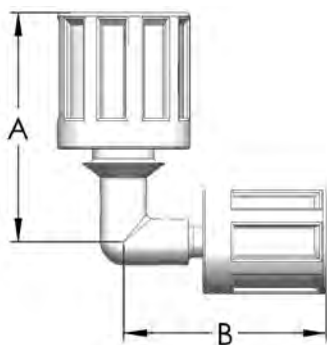

Union Elbow Sweep				
U.S. Patent 6,164,706; 6,426,031				
PFA Part No.	Tube O.D.	Orifice	A	B
UES44N-1	1/4	.15	1.62	1.62
UES66N-1	3/8	.25	1.83	1.83
UES88N-1	1/2	.38	2.05	2.05
UES1212N-1	3/4	.63	2.33	2.33
UES1616N-1	1	.88	2.78	2.78

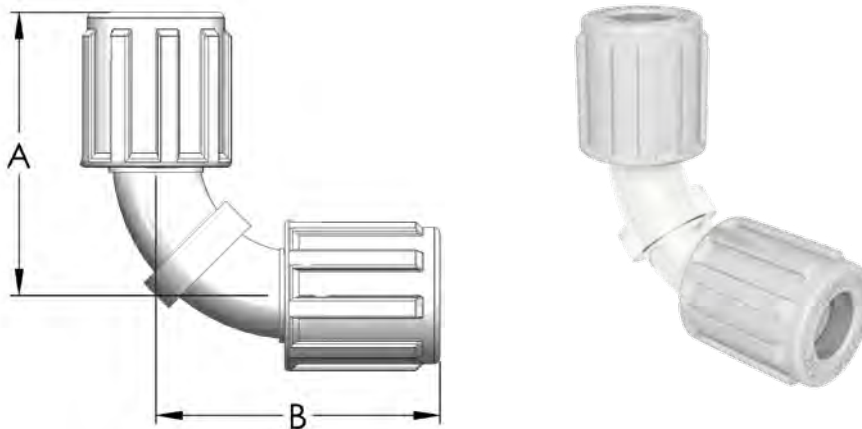

Union Elbow Sweep (TightFLARE™)				
(Male x Female Flare)				
U.S. Patent 6,164,706; 6,426,031; 7,055,870				
PFA Part No.	Tube O.D. / TightFLARE™	Orifice	A	B
UES44TN-1	1/4	.15	1.62	1.78
UES66TN-1	3/8	.25	1.83	1.97
UES88TN-1	1/2	.38	2.05	2.15
UES1212TN-1	3/4	.63	2.33	2.56
UES1616TN-1	1	.88	2.78	3.22

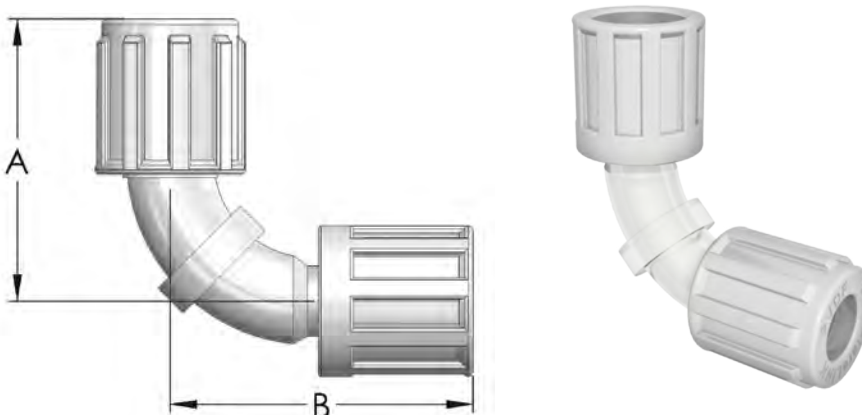

<b>Union Elbow Sweep (TightFLARE™)</b> (Female Flare x Female Flare) U.S. Patent 6,164,706; 6,426,031; 7,055,870				
PFA Part No.	TightFLARE™	Orifice	A	B
UES4TN-1	1/4	.15	1.78	1.78
UES6TN-1	3/8	.25	1.97	1.97
UES8TN-1	1/2	.38	2.15	2.15
UES12TN-1	3/4	.63	2.56	2.56
UES16TN-1	1	.88	3.22	3.22

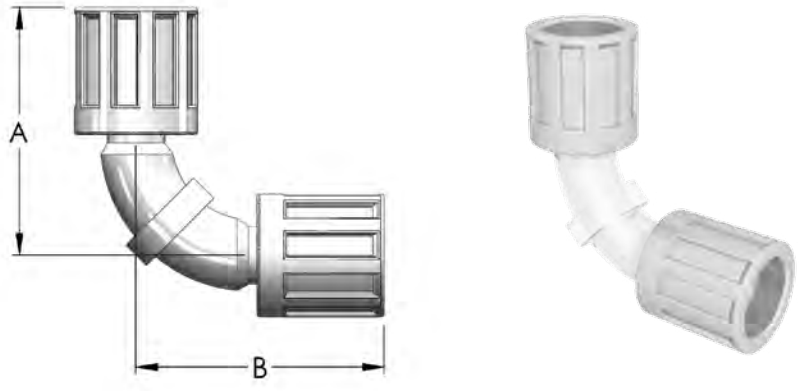

<b>Male Elbow Sweep</b> U.S. Patent 6,164,706; 6,426,031				
PFA Part No.	Tube O.D. / NPT	Orifice	A	B
MES4-4N-1	1/4	.15	1.62	1.20
MES6-6N-1	3/8	.25	1.83	1.32
MES8-8N-1	1/2	.38	2.05	1.55
MES12-12N-1	3/4	.63	2.33	1.76
MES16-16N-1	1	.88	2.78	2.26

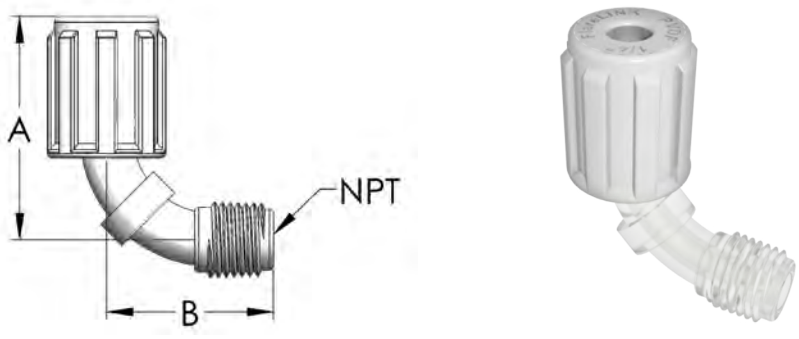

Male Elbow Sweep (TightFLARE™)				
U.S. Patent 6,164,706; 6,426,031; 7,055,870				
PFA Part No.	TightFLARE™ / NPT	Orifice	A	B
MES4T-4N-1	1/4	.15	1.78	1.20
MES6T-6N-1	3/8	.25	1.97	1.32
MES8T-8N-1	1/2	.38	2.15	1.55
MES12T-12N-1	3/4	.63	2.56	1.76
MES16T-16N-1	1	.88	3.22	2.26

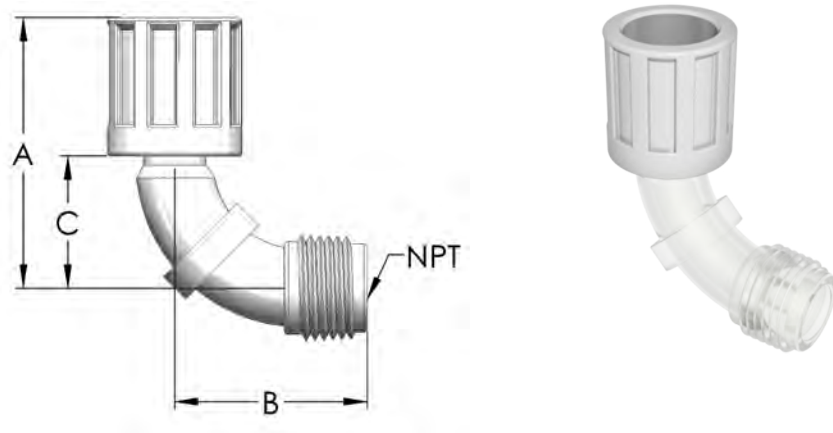

Union Tee					
PFA Part No.	PVDF Part No.	Tube O.D.	Orifice	A	B
UT4N-1	UT4	1/4	.15	3.32	1.66
UT6N-1	UT6	3/8	.25	3.52	1.76
UT8N-1	UT8	1/2	.38	3.74	1.87
UT12N-1	UT12	3/4	.63	4.44	2.22
UT16N-1	UT16	1	.88	5.40	2.70
UT20N-1		1-1/4	1.10	5.92	2.96

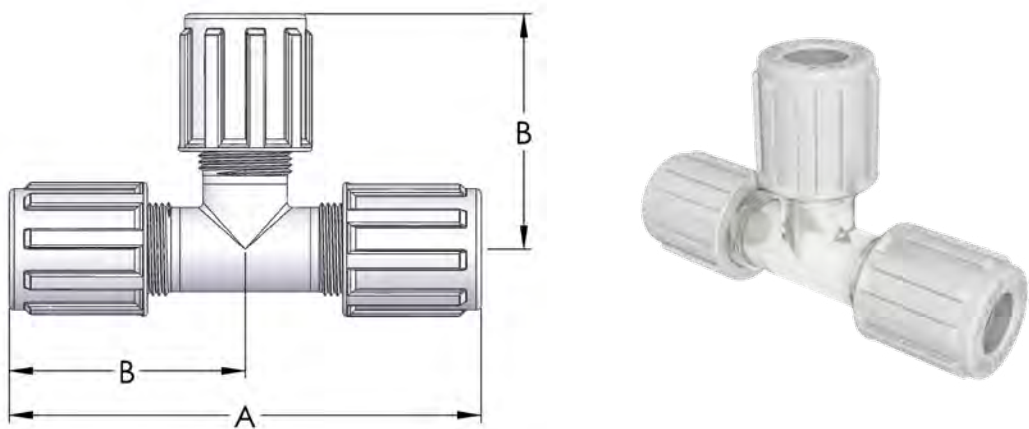



Union Tee Reducer								
PFA Part No.	X	Y	Z	Orifice	A	B1	B2	C
UT4-6-4N-1	1/4	3/8	1/4	.15	3.32	1.66	1.66	1.76
UT4-8-4N-1	1/4	1/2	1/4	.15	3.32	1.66	1.66	1.87
UT6-4-4N-1	3/8	1/4	1/4	.15	3.42	1.76	1.66	1.66
UT6-4-6N-1	3/8	1/4	3/8	.15	3.52	1.76	1.76	1.66
UT6-6-4N-1	3/8	3/8	1/4	.15	3.42	1.76	1.66	1.76
UT6-6-6N-1	3/8	1/2	3/8	.25	3.52	1.76	1.76	1.87
UT8-4-4N-1	1/2	1/4	1/4	.15	3.53	1.87	1.66	1.66
UT8-4-6N-1	1/2	1/4	3/8	.15	3.63	1.87	1.76	1.66
UT8-4-8N-1	1/2	1/4	1/2	.15	3.74	1.87	1.87	1.66
UT8-6-6N-1	1/2	3/8	3/8	.25	3.63	1.87	1.76	1.76
UT8-6-8N-1	1/2	3/8	1/2	.25	3.74	1.87	1.87	1.76
UT8-8-4N-1	1/2	1/2	1/4	.15	3.53	1.87	1.66	1.87
UT8-8-6N-1	1/2	1/2	3/8	.38	3.63	1.87	1.76	1.87
UT8-12-8N-1	1/2	3/4	1/2	.38	3.72	1.86	1.86	2.22
UT12-4-12N-1	3/4	1/4	3/4	.15	4.44	2.22	2.22	1.66
UT12-6-12N-1	3/4	3/8	3/4	.25	4.44	2.22	2.22	1.76
UT12-8-8N-1	3/4	1/2	1/2	.38	4.09	2.22	1.87	1.87
UT12-8-12N-1	3/4	1/2	3/4	.38	4.44	2.22	2.22	1.87
UT12-12-6N-1	3/4	3/4	3/8	.25	3.98	2.22	1.76	2.22
UT12-12-8N-1	3/4	3/4	1/2	.38	4.09	2.22	1.87	2.22
UT12-16-12N-1	3/4	1	3/4	.63	4.44	2.22	2.22	2.70
UT16-4-16N-1	1	1/4	1	.15	5.40	2.70	2.70	2.02
UT16-6-16N-1	1	3/8	1	.25	5.40	2.70	2.70	2.13
UT16-8-16N-1	1	1/2	1	.38	5.40	2.70	2.70	2.26
UT16-12-16N-1	1	3/4	1	.63	5.40	2.70	2.70	2.22
UT16-12-12N-1	1	3/4	3/4	.63	4.92	2.70	2.22	2.22
UT16-16-8N-1	1	1	1/2	.38	4.92	2.70	2.22	2.70
UT16-16-12N-1	1	1	3/4	.63	4.92	2.70	2.22	2.70

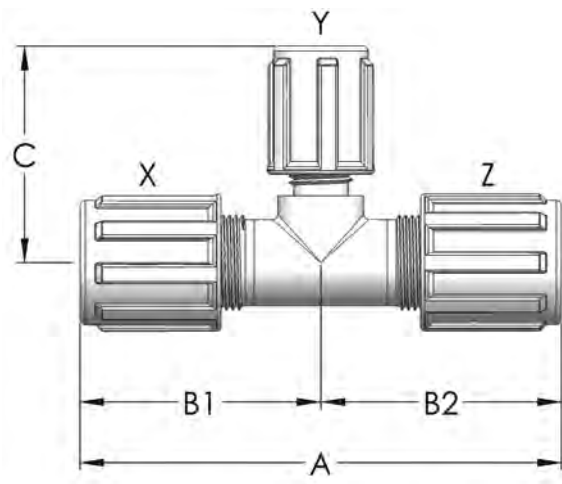

Union Tee (TightFLARE™) Branch U.S. Patent 7,055,870								
PFA Part No.	X	Y	Z	Orifice	A	B1	B2	C
UT4-4T-4N-1	1/4	1/4	1/4	.15	3.32	1.66	1.66	1.64
UT4-6T-4N-1	1/4	3/8	1/4	.15	3.32	1.66	1.66	1.73
UT6-4T-6N-1	3/8	1/4	3/8	.15	3.52	1.76	1.76	1.64
UT6-6T-4N-1	3/8	3/8	1/4	.15	3.42	1.76	1.66	1.73
UT6-6T-6N-1	3/8	3/8	3/8	.25	3.52	1.76	1.76	1.73
UT6-8T-6N-1	3/8	1/2	3/8	.25	3.52	1.76	1.76	1.84
UT8-4T-8N-1	1/2	1/4	1/2	.15	3.74	1.87	1.87	1.64
UT8-6T-8N-1	1/2	3/8	1/2	.25	3.74	1.87	1.87	1.73
UT8-8T-4N-1	1/2	1/2	1/4	.15	3.53	1.87	1.66	1.84
UT8-8T-6N-1	1/2	1/2	3/8	.25	3.63	1.87	1.76	1.84
UT8-8T-8N-1	1/2	1/2	1/2	.38	3.74	1.87	1.87	1.84
UT8-12T-8N-1	1/2	3/4	1/2	.38	3.74	1.87	1.87	2.13
UT12-4T-12N-1	3/4	1/4	3/4	.15	4.44	2.22	2.22	1.64
UT12-6T-12N-1	3/4	3/8	3/4	.25	4.44	2.22	2.22	1.73
UT12-8T-8N-1	3/4	1/2	1/2	.38	4.09	2.22	1.87	1.84
UT12-8T-12N-1	3/4	1/2	3/4	.38	4.44	2.22	2.22	1.97
UT12-12T-6N-1	3/4	3/4	3/8	.25	3.98	2.22	1.76	2.13
UT12-12T-8N-1	3/4	3/4	1/2	.38	4.09	2.22	1.87	2.13
UT12-12T-12N-1	3/4	3/4	3/4	.63	4.44	2.22	2.22	2.13
UT12-16T-12N-1	3/4	1	3/4	.63	4.44	2.22	2.22	2.74
UT16-8T-16N-1	1	1/2	1	.38	5.40	2.70	2.70	2.09
UT16-12T-12N-1	1	3/4	3/4	.63	4.92	2.70	2.22	2.13
UT16-12T-16N-1	1	3/4	1	.63	5.40	2.70	2.70	2.23
UT16-16T-16N-1	1	1	1	.88	5.40	2.70	2.70	2.74
UT20-20T-20N-1	1-1/4	1-1/4	1-1/4	1.10	5.92	2.96	2.96	3.10

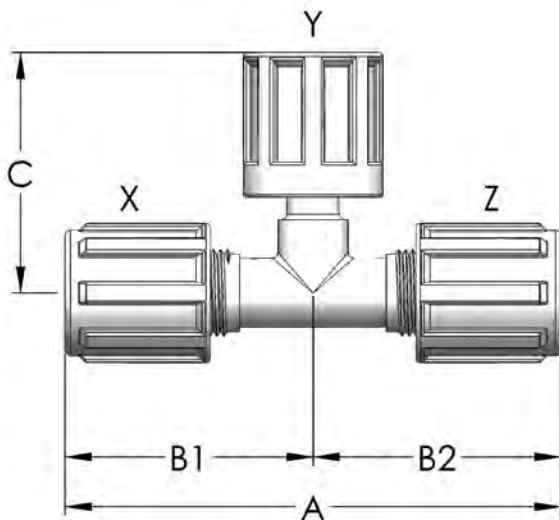

Union Tee (TightFLARE™) Run U.S. Patent 7,055,870								
PFA Part No.	X	Y	Z	Orifice	A	B1	B2	C
UT4-4-4TN-1	1/4	1/4	1/4	.15	3.30	1.66	1.64	1.66
UT4-8-8TN-1	1/4	1/2	1/2	.15	3.50	1.66	1.84	1.87
UT6-4-6TN-1	3/8	1/4	3/8	.15	3.49	1.76	1.73	1.66
UT6-6-6TN-1	3/8	3/8	3/8	.25	3.49	1.76	1.73	1.76
UT6-6-8TN-1	3/8	3/8	1/2	.25	3.60	1.76	1.84	1.76
UT6-8-8TN-1	3/8	1/2	1/2	.25	3.60	1.76	1.84	1.87
UT6-12-12TN-1	3/8	3/4	3/4	.25	3.89	1.76	2.13	2.22
UT8-4-8TN-1	1/2	1/4	1/2	.15	3.71	1.87	1.84	1.66
UT8-6-6TN-1	1/2	3/8	3/8	.25	3.60	1.87	1.73	1.76
UT8-6-8TN-1	1/2	3/8	1/2	.25	3.71	1.87	1.84	1.76
UT8-8-6TN-1	1/2	1/2	3/8	.25	3.60	1.87	1.73	1.87
UT8-8-8TN-1	1/2	1/2	1/2	.38	3.71	1.87	1.84	1.87
UT8-8-12TN-1	1/2	1/2	3/4	.38	4.00	1.87	2.13	1.87
UT12-4-12TN-1	3/4	1/4	3/4	.15	4.35	2.22	2.13	1.66
UT12-6-12TN-1	3/4	3/8	3/4	.25	4.35	2.22	2.13	1.76
UT12-8-12TN-1	3/4	1/2	3/4	.38	4.35	2.22	2.13	1.87
UT12-12-8TN-1	3/4	3/4	1/2	.38	4.06	2.22	1.84	2.22
UT12-12-12TN-1	3/4	3/4	3/4	.63	4.35	2.22	2.13	2.22
UT16-4-16TN-1	1	1/4	1	.15	5.44	2.70	2.74	2.02
UT16-6-16TN-1	1	3/8	1	.25	5.44	2.70	2.74	2.13
UT16-8-16TN-1	1	1/2	1	.38	5.44	2.70	2.74	2.26
UT16-12-16TN-1	1	3/4	1	.63	5.44	2.70	2.74	2.22
UT16-16-12TN-1	1	1	3/4	.63	4.94	2.70	2.24	2.70
UT16-16-16TN-1	1	1	1	.88	5.44	2.70	2.74	2.70
UT20-20-20TN-1	1-1/4	1-1/4	1-1/4	1.10	6.06	2.96	3.10	2.96

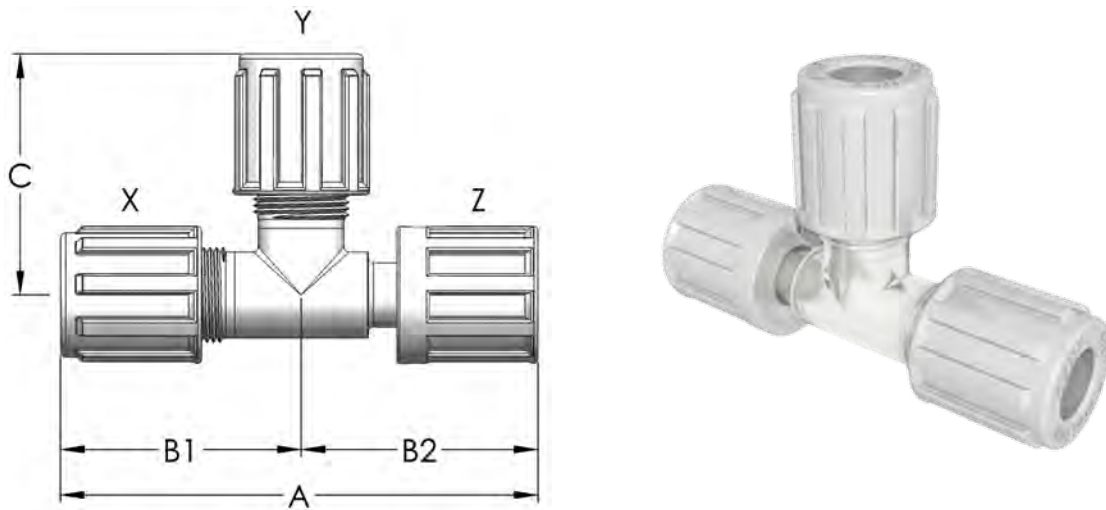

Union Tee (TightFLARE™) Branch, Run U.S. Patent 7,055,870								
PFA Part No.	X	Y	Z	Orifice	A	B1	B2	C
UT4-4T-4TN-1	1/4	1/4	1/4	.15	3.30	1.66	1.64	1.64
UT6-4T-6TN-1	3/8	1/4	3/8	.15	3.49	1.76	1.73	1.64
UT6-6T-6TN-1	3/8	3/8	3/8	.25	3.49	1.76	1.73	1.73
UT6-8T-8TN-1	3/8	1/2	1/2	.25	3.60	1.76	1.84	1.84
UT6-12T-12TN-1	3/8	3/4	3/4	.25	3.89	1.76	2.13	2.13
UT8-6T-6TN-1	1/2	3/8	3/8	.25	3.60	1.87	1.73	1.73
UT8-6T-8TN-1	1/2	3/8	1/2	.25	3.71	1.87	1.84	1.73
UT8-8T-8TN-1	1/2	1/2	1/2	.38	3.71	1.87	1.84	1.84
UT8-8T-12TN-1	1/2	1/2	3/4	.38	4.00	1.87	2.13	1.84
UT8-12T-12TN-1	1/2	3/4	3/4	.38	4.00	1.87	2.13	2.13
UT12-8T-8TN-1	3/4	1/2	1/2	.38	4.06	2.22	1.84	1.84
UT12-8T-12TN-1	3/4	1/2	3/4	.38	4.35	2.22	2.13	1.84
UT12-12T-8TN-1	3/4	3/4	1/2	.38	4.06	2.22	1.84	2.13
UT12-12T-12TN-1	3/4	3/4	3/4	.63	4.35	2.22	2.13	2.13
UT16-12T-12TN-1	1	3/4	3/4	.63	4.83	2.70	2.13	2.13
UT16-12T-16TN-1	1	3/4	1	.63	5.44	2.70	2.74	2.13
UT16-16T-12TN-1	1	1	3/4	.63	4.94	2.70	2.24	2.74
UT16-16T-16TN-1	1	1	1	.88	5.44	2.70	2.74	2.74
UT20-16T-20TN-1	1-1/4	1	1-1/4	.88	6.06	2.96	3.10	2.59
UT20-20T-20TN-1	1-1/4	1-1/4	1-1/4	1.10	6.06	2.96	3.10	3.10

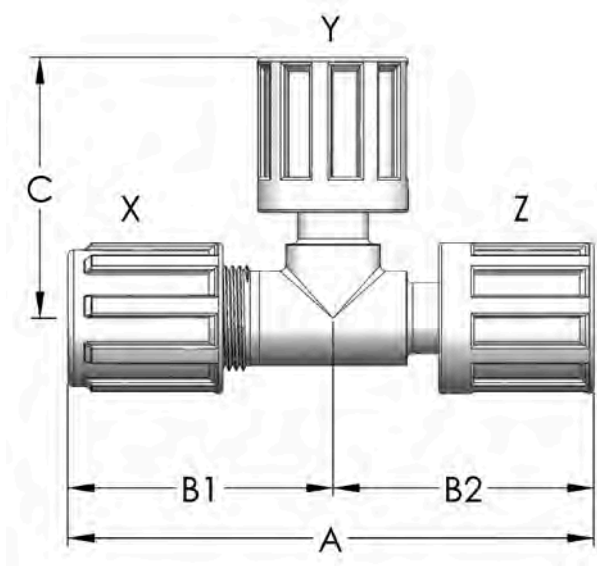

### Union Tee (TightFLARE™) Run, Run

U.S. Patent 7,055,870

PFA Part No.	X	Y	Z	Orifice	A	B1	B2	C
UT4T-4-4TN-1	1/4	1/4	1/4	.15	3.28	1.64	1.64	1.66
UT4T-6-4TN-1	1/4	3/8	1/4	.15	3.28	1.64	1.64	1.76
UT6T-4-6TN-1	3/8	1/4	3/8	.15	3.46	1.73	1.73	1.66
UT6T-6-6TN-1	3/8	3/8	3/8	.25	3.46	1.73	1.73	1.76
UT6T-8-6TN-1	3/8	1/2	3/8	.25	3.46	1.73	1.73	1.87
UT8T-4-8TN-1	1/2	1/4	1/2	.15	3.68	1.84	1.84	1.66
UT8T-6-6TN-1	1/2	3/8	3/8	.25	3.57	1.84	1.73	1.76
UT8T-8-4TN-1	1/2	1/2	1/4	.15	3.48	1.84	1.64	1.87
UT8T-8-6TN-1	1/2	1/2	3/8	.25	3.57	1.84	1.73	1.87
UT8T-8-8TN-1	1/2	1/2	1/2	.38	3.68	1.84	1.84	1.87
UT8T-12-8TN-1	1/2	3/4	1/2	.38	3.68	1.84	1.84	2.22
UT12T-4-12TN-1	3/4	1/4	3/4	.15	4.26	2.13	2.13	1.66
UT12T-6-12TN-1	3/4	3/8	3/4	.25	4.26	2.13	2.13	1.76
UT12T-8-8TN-1	3/4	1/2	1/2	.38	3.97	1.84	2.13	1.87
UT12T-8-12TN-1	3/4	1/2	3/4	.38	4.26	2.13	2.13	1.87
UT12T-12-12TN-1	3/4	3/4	3/4	.63	4.26	2.13	2.13	2.22
UT12T-16-12TN-1	3/4	1	3/4	.63	4.26	2.13	2.13	2.70
UT16T-6-16TN-1	1	3/8	1	.25	5.48	2.74	2.74	2.13
UT16T-8-16TN-1	1	1/2	1	.38	5.48	2.74	2.74	2.26
UT16T-12-16TN-1	1	3/4	1	.63	5.48	2.74	2.74	2.21
UT16T-16-16TN-1	1	1	1	.88	5.48	2.74	2.74	2.70
UT20T-20-20TN-1	1-1/4	1-1/4	1-1/4	1.10	6.20	3.10	3.10	2.96

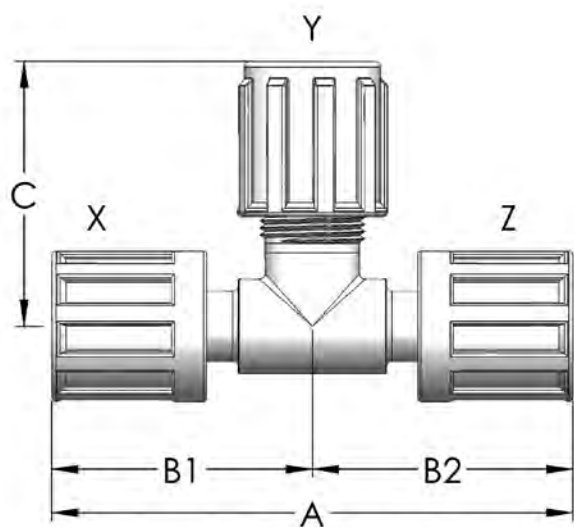

Union Tee (TightFLARE™) All U.S. Patent 7,055,870								
PFA Part No.	X	Y	Z	Orifice	A	B1	B2	C
UT4TN-1	1/4	1/4	1/4	.15	3.28	1.64	1.64	1.64
UT4T-6T-4TN-1	1/4	3/8	1/4	.15	3.28	1.64	1.64	1.73
UT6TN-1	3/8	3/8	3/8	.25	3.46	1.73	1.73	1.73
UT6T-8T-4TN-1	3/8	1/2	1/4	.15	3.37	1.73	1.64	1.84
UT8TN-1	1/2	1/2	1/2	.38	3.68	1.84	1.84	1.84
UT8T-6T-6TN-1	1/2	3/8	3/8	.25	3.57	1.84	1.73	1.73
UT8T-8T-4TN-1	1/2	1/2	1/4	.15	3.48	1.84	1.64	1.84
UT8T-12T-8TN-1	1/2	3/4	1/2	.38	3.68	1.84	1.84	2.13
UT12TN-1	3/4	3/4	3/4	.63	4.26	2.13	2.13	2.13
UT12T-6T-12TN-1	3/4	3/8	3/4	.25	4.26	2.13	2.13	1.73
UT12T-8T-12TN-1	3/4	1/2	3/4	.38	4.23	2.13	2.13	1.84
UT12T-12T-8TN-1	3/4	3/4	1/2	.38	3.97	2.13	1.84	2.13
UT16T-12T-16TN-1	1	3/4	1	.63	5.48	2.74	2.74	2.13
UT16TN-1	1	1	1	.88	5.48	2.74	2.74	2.74
UT20TN-1	1-1/4	1-1/4	1-1/4	1.10	6.20	3.10	3.10	3.10

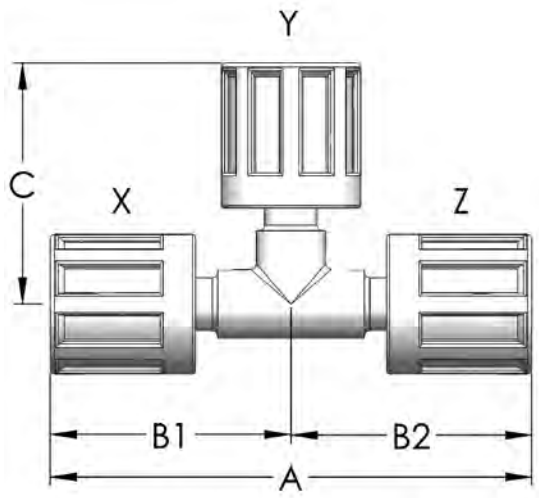



Male Run Tee							
PFA Part No.	PVDF Part No.	Tube O.D.	Tube O.D.	NPT Size	Orifice	A	B
MRT44-2N-1	MRT44-2	1/4	1/4	1/8	.15	2.72	1.68
MRT44-4N-1	MRT44-4	1/4	1/4	1/4	.15	2.72	1.68
MRT44-6N-1		1/4	1/4	3/8	.15	2.72	1.68
MRT66-2N-1		3/8	3/8	1/8	.17	2.83	1.76
MRT66-4N-1		3/8	3/8	1/4	.25	2.83	1.76
MRT66-6N-1	MRT66-6	3/8	3/8	3/8	.25	2.83	1.76
MRT66-8N-1		3/8	3/8	1/2	.25	2.83	1.76
MRT88-6N-1		1/2	1/2	3/8	.38	2.96	1.87
MRT88-8N-1	MRT88-8	1/2	1/2	1/2	.38	3.04	1.87
MRT1212-6N-1		3/4	3/4	3/8	.38	3.45	2.22
MRT1212-8N-1		3/4	3/4	1/2	.49	3.56	2.22
MRT1212-12N-1	MRT1212-12	3/4	3/4	3/4	.63	3.59	2.22
MRT1616-12N-1		1	1	3/4	.63	4.34	2.70
MRT1616-16N-1	MRT1616-16	1	1	1	.88	4.50	2.70

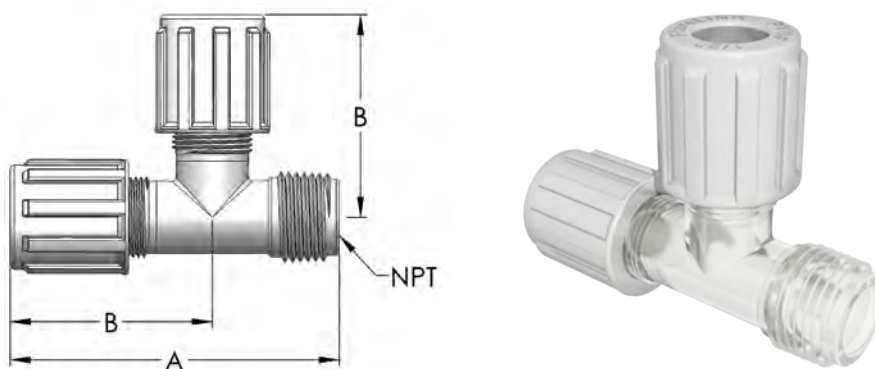

Male Branch Tee (TightFLARE™)						
U.S. Patent 7,055,870						
PFA Part No.	TightFLARE™	NPT Size	Orifice	A	B	C
MBT12T12T-8N-1	3/4	1/2	.49	4.24	2.12	1.35
MBT16T16T-8N-1	1	1/2	.49	5.48	2.74	1.63
MBT16T16T-16N-1	1	1	.88	5.48	2.74	1.81

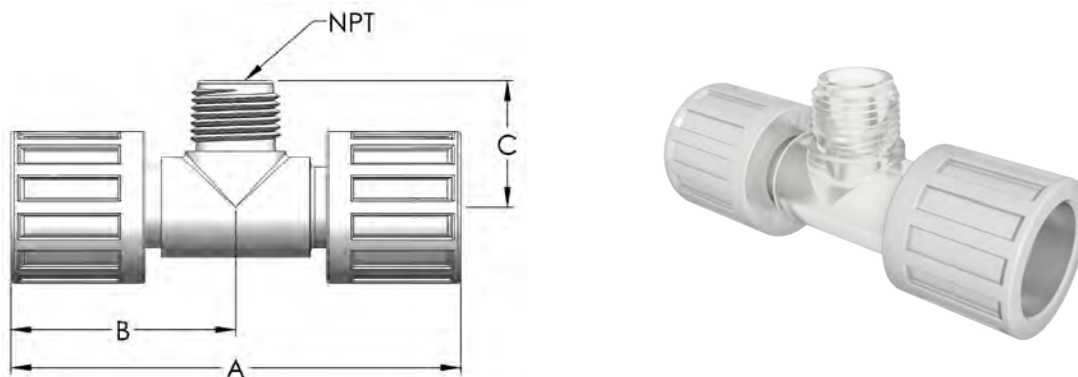

Male Branch Tee								
PFA Part No.	PVDF Part No.	Tube O.D.	Tube O.D.	NPT Size	Orifice	A	B	C
MBT44-2N-1		1/4	1/4	1/8	.15	3.32	1.66	1.07
MBT44-4N-1	MBT44-4	1/4	1/4	1/4	.15	3.32	1.66	1.07
MBT44-8N-1		1/4	1/4	1/2	.15	3.32	1.66	1.17
MBT64-4N-1		3/8	1/4	1/4	.15	3.42	1.76	1.07
MBT64-6N-1		3/8	1/4	3/8	.15	3.52	1.76	1.07
MBT66-2N-1		3/8	3/8	1/8	.25	3.52	1.76	1.07
MBT66-4N-1	MBT66-4	3/8	3/8	1/4	.25	3.52	1.76	1.07
MBT66-6N-1	MBT66-6	3/8	3/8	3/8	.25	3.52	1.76	1.07
MBT66-8N-1		3/8	3/8	1/2	.25	3.52	1.76	1.17
MBT84-8N-1		1/2	1/4	1/2	.15	3.53	1.87	1.17
MBT86-6N-1		1/2	3/8	3/8	.25	3.64	1.87	1.08
MBT86-8N-1		1/2	3/8	1/2	.25	3.64	1.87	1.17
MBT88-4N-1		1/2	1/2	1/4	.25	3.74	1.87	1.07
MBT88-6N-1		1/2	1/2	3/8	.38	3.74	1.87	1.08
MBT88-8N-1	MBT88-8	1/2	1/2	1/2	.38	3.74	1.87	1.17
MBT88-12N-1		1/2	1/2	3/4	.38	3.74	1.87	1.35
MBT1212-4N-1		3/4	3/4	1/4	.25	4.44	2.22	1.27
MBT1212-8N-1		3/4	3/4	1/2	.51	4.44	2.22	1.35
MBT1212-12N-1	MBT1212-12	3/4	3/4	3/4	.63	4.44	2.22	1.35
MBT1616-4N-1		1	1	1/4	.25	5.40	2.70	1.57
MBT1616-6N-1		1	1	3/8	.38	5.40	2.70	1.57
MBT1616-8N-1		1	1	1/2	.51	5.40	2.70	1.63
MBT1616-12N-1		1	1	3/4	.69	5.40	2.70	1.63
MBT1616-16N-1	MBT1616-16	1	1	1	.88	5.40	2.70	1.81
MBT2020-8N-1		1-1/4	1-1/4	1/2	.51	5.92	2.96	2.00

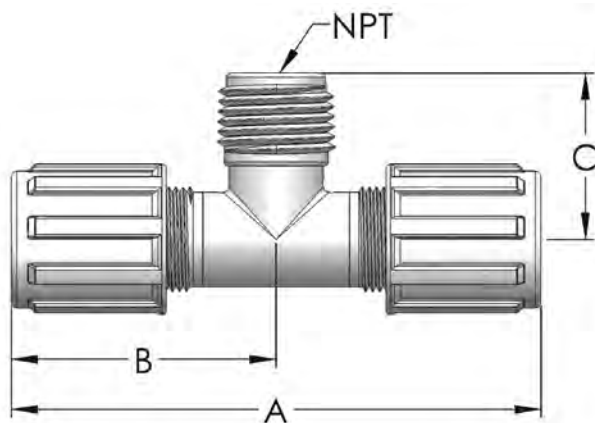

Female Run Tee						
PFA Part No.	Tube O.D.	Tube O.D.	NPT Size	Orifice	A	B
FRT1212-12N-1	3/4	3/4	3/4	.63	3.75	2.22

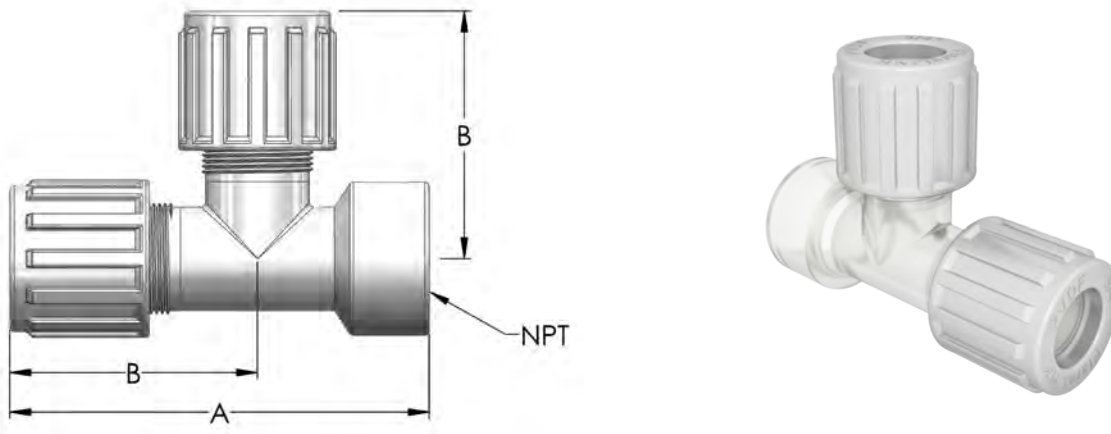

Female Branch Tee						
PFA Part No.	NPT	Tube O.D.	Orifice	A	B	C
FBT1212-4N-1	1/4	3/4	.25	4.44	2.22	1.43
FBT1212-12N-1	3/4	3/4	.63	4.44	2.22	1.53
FBT1616-4N-1	1/4	1	.25	5.40	2.70	1.43
FBT1616-8N-1	1/2	1	.51	5.40	2.70	1.38

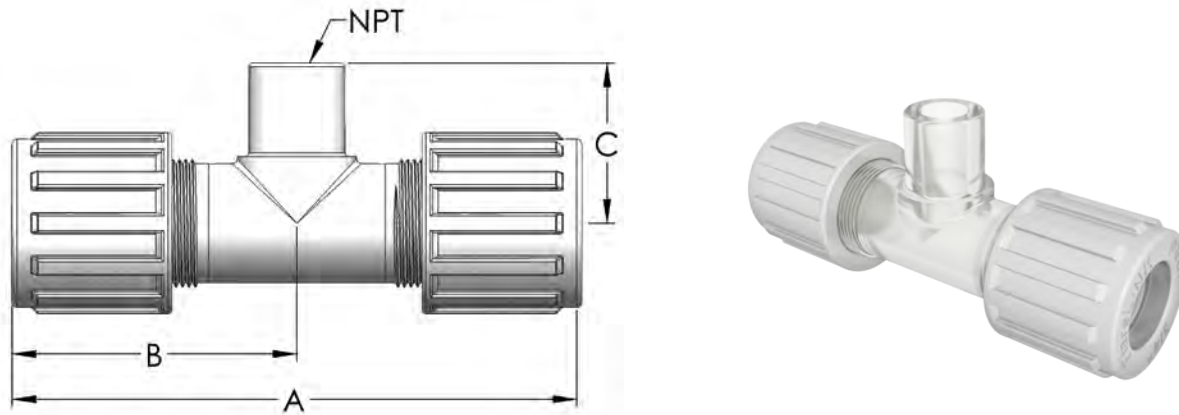

Flare Plug and Nut								
PFA Flare Plug Part No.	Part No.	Tube O.D.	A	Hex	PFA Flare Plug & Nut Part No.	A	B	Hex
FP4		1/4	1.25	5/8	FP4N-1	1.47	.73	5/8
FP6		3/8	1.34	13/16	FP6N-1	1.57	.85	13/16
FP8		1/2	1.43	15/16	FP8N-1	1.67	1.00	15/16
FP12		3/4	1.58	1-3/16	FP12N-1	1.79	1.32	1-3/16
FP16		1	1.75	1-7/16	FP16N-1	2.01	1.76	1-7/16
FP20		1-1/4	2.13	1-3/4	FP20N-1	2.63	1.96	1-3/4

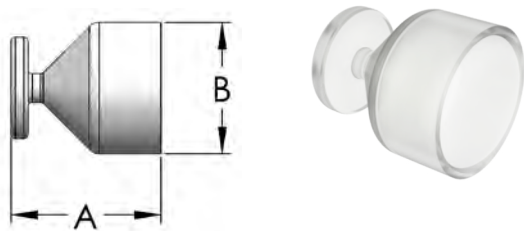
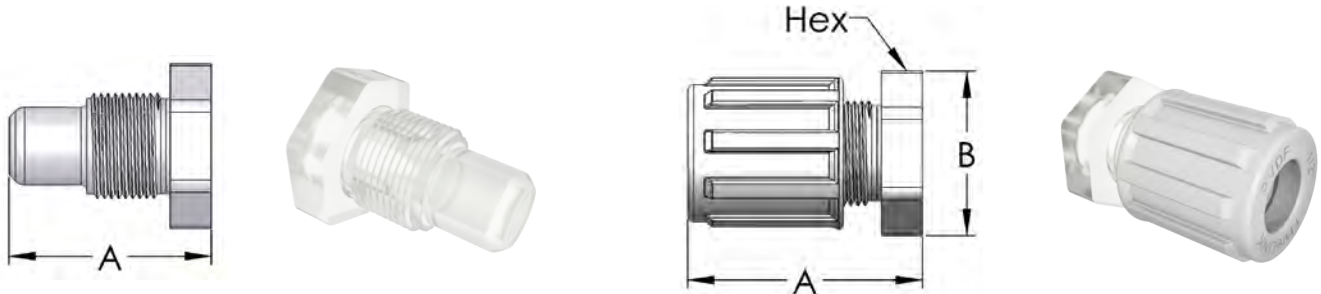

Flare Cap			
PFA Part No.	Flare Size	A	B
FCAP4	1/4	.93	.39
FCAP6	3/8	1.01	.53
FCAP8	1/2	1.03	.68
FCAP12	3/4	1.10	.93
FCAP16	1	1.28	1.26
FCAP20	1-1/4	1.73	1.57

Flare Nut PFA			
PFA Part No.	Tube O.D.	A	B
N4-3	1/4	1.02	.84
N6-3	3/8	1.03	.99
N8-3	1/2	1.12	1.07
N12-3	3/4	1.27	1.41
N16-3	1	1.51	1.85
N20-3	1-1/4	1.86	2.32

Flare Nut PVDF			
PVDF Part No.	Tube O.D.	A	B
N4-1	1/4	1.00	.73
N6-1	3/8	1.01	.85
N8-1	1/2	1.09	1.00
N12-1	3/4	1.25	1.32
N16-1	1	1.49	1.76
N20-1	1-1/4	1.83	2.20

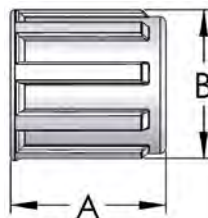

Panel Mount Nut (Half Nut) PFA			
PFA Part No.	Hex	A	B
PMN4-3	13/16	.29	1/2-20 UNF
PMN6-3	1	.29	5/8-20 UN
PMN8-3	1-1/8	.30	3/4-20 UNEF
PMN12-3	1-3/8	.32	1-20 UNEF
PMN16-3	1-7/8	.34	1-7/16-12 UN

Panel Mount Nut (Half Nut) PVDF			
PVDF Part No.	Hex	A	B
PMN4-1	3/4	.26	1/2-20 UNF
PMN6-1	15/16	.26	5/8-20 UN
PMN8-1	1-1/16	.27	3/4-20 UNEF
PMN12-1	1-5/16	.28	1-20 UNEF
PMN16-1	1-3/4	.27	1-7/16-12 UN

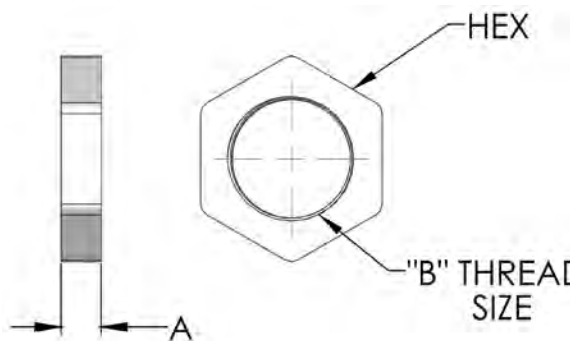

Weld Straight Connector (Pipe x Male Flare)								
PFA Part No.	Pipe Size	Tube Size	Orifice	A	B	C	D	Hex
WSC4P-4N-1	1/4	1/4	.15	2.02	.54	.35	.55	5/8
WSC4P-6N-1	1/4	3/8	.25	2.12	.54	.35	.55	11/16
WSC4P-8N-1	1/4	1/2	.35	2.21	.54	.35	.55	13/16
WSC8P-4N-1	1/2	1/4	.15	3.15	.84	.61	1.50	1
WSC8P-6N-1	1/2	3/8	.25	3.26	.84	.61	1.50	1
WSC8P-8N-1	1/2	1/2	.38	3.36	.84	.61	1.50	1
WSC8P-12N-1	1/2	3/4	.61	3.50	.84	.61	1.50	1-3/16
WSC12P-4N-1	3/4	1/4	.15	3.15	1.05	.81	1.50	1-3/16
WSC12P-6N-1	3/4	3/8	.25	3.26	1.05	.81	1.50	1-3/16
WSC12P-8N-1	3/4	1/2	.38	3.36	1.05	.81	1.50	1-3/16
WSC12P-12N-1	3/4	3/4	.63	3.50	1.05	.81	1.50	1-3/16
WSC12P-16N-1	3/4	1	.81	3.71	1.05	.81	1.50	1-7/16
WSC16P-8N-1	1	1/2	.38	2.63	1.32	1.05	1.50	1-7/16
WSC16P-12N-1	1	3/4	.63	3.50	1.32	1.03	1.50	1-7/16
WSC16P-16N-1	1	1	.88	3.71	1.32	1.03	1.50	1-7/16

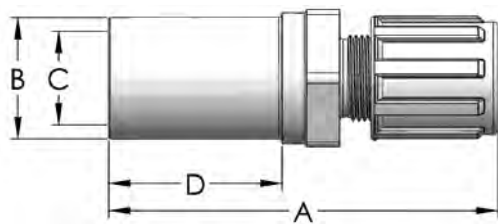

Weld Straight Connector (TightFLARE™) (Pipe x Female Flare) U.S. Patent 7,055,870							
PFA Part No.	Pipe Size	TightFLARE™	Orifice	A	B	C	D
WSC4P-4TN-1	1/4	1/4	.15	2.17	.54	.35	.55
WSC4P-6TN-1	1/4	3/8	.25	2.21	.54	.35	.55
WSC8P-6TN-1	1/2	3/8	.25	3.38	.84	.61	1.50
WSC8P-8TN-1	1/2	1/2	.38	3.42	.84	.61	1.50
WSC8P-12TN-1	1/2	3/4	.61	3.58	.84	.61	1.50
WSC12P-8TN-1	3/4	1/2	.38	3.42	1.05	.81	1.50
WSC12P-12TN-1	3/4	3/4	.63	3.58	1.05	.81	1.50
WSC12P-16TN-1	3/4	1	.81	4.02	1.05	.81	1.50
WSC16P-8TN-1	1	1/2	.38	3.42	1.32	1.03	1.50
WSC16P-12TN-1	1	3/4	.63	3.58	1.32	1.03	1.50
WSC16P-16TN-1	1	1	.88	4.02	1.32	1.03	1.50
WSC16P-20TN-1	1	1-1/4	1.03	4.44	1.32	1.03	1.50

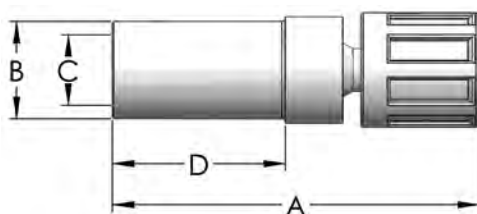



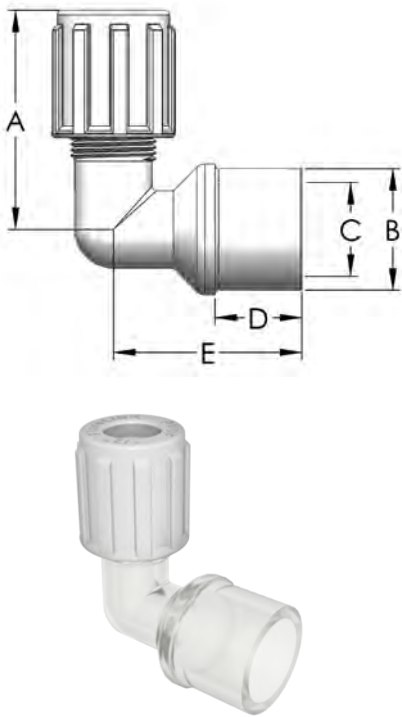

Weld Elbow Connector (Pipe x Male Flare)								
PFA Part No.	Pipe Size	Tube Size	Orifice	A	B	C	D	E
WEC4P-4N-1	1/4	1/4	.15	1.66	.54	.35	.75	1.27
WEC4P-6N-1	1/4	3/8	.25	1.76	.54	.35	.75	1.27
WEC8P-4N-1	1/2	1/4	.15	1.66	.84	.61	.75	1.44
WEC8P-6N-1	1/2	3/8	.25	1.76	.84	.61	.75	1.44
WEC8P-8N-1	1/2	1/2	.38	1.87	.84	.61	.75	1.44
WEC8P-12N-1	1/2	3/4	.61	2.22	.84	.61	.79	1.50
WEC12P-4N-1	3/4	1/4	.15	1.66	1.05	.81	.84	1.71
WEC12P-8N-1	3/4	1/2	.38	1.87	1.05	.81	.84	1.71
WEC12P-12N-1	3/4	3/4	.63	2.22	1.05	.81	.84	1.71
WEC12P-16N-1	3/4	1	.63	2.70	1.05	.81	1.05	1.71
WEC16P-12N-1	1	3/4	.63	2.22	1.32	1.03	.75	1.72
WEC16P-16N-1	1	1	.88	2.70	1.32	1.03	.75	1.72

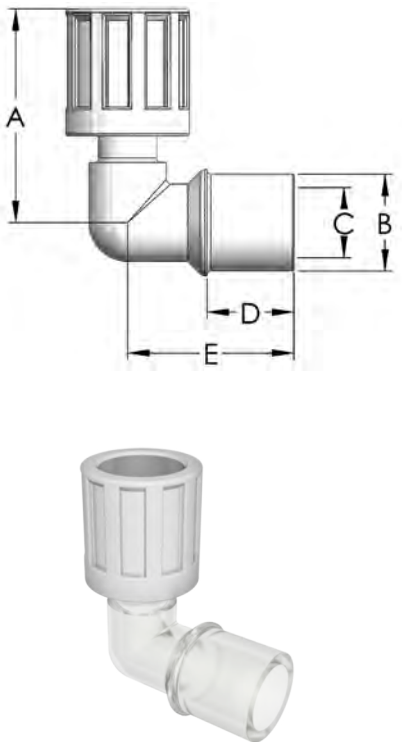

Weld Elbow Connector (TightFLARE™) (Pipe x Female Flare) U.S. Patent 7,055,870								
PFA Part No.	Pipe Size	TightFLARE™	Orifice	A	B	C	D	E
WEC4P-4TN-1	1/4	1/4	.15	1.64	.54	.35	.75	1.27
WEC4P-6TN-1	1/4	3/8	.25	1.73	.54	.35	.75	1.27
WEC8P-4TN-1	1/2	1/4	.15	1.64	.84	.61	.75	1.44
WEC8P-6TN-1	1/2	3/8	.25	1.73	.84	.61	.75	1.44
WEC8P-8TN-1	1/2	1/2	.38	1.84	.84	.61	.75	1.44
WEC8P-12TN-1	1/2	3/4	.61	2.13	.84	.61	.79	1.50
WEC12P-8TN-1	3/4	1/2	.38	1.84	1.05	.81	.84	1.71
WEC12P-12TN-1	3/4	3/4	.63	2.13	1.05	.81	.84	1.71
WEC12P-16TN-1	3/4	1	.81	2.74	1.05	.81	1.05	1.71
WEC16P-12TN-1	1	3/4	.63	2.13	1.32	1.03	.75	1.72
WEC16P-16TN-1	1	1	.88	2.74	1.32	1.03	.75	1.72

Weld Straight Reducer (Pipe x Pipe)										
PFA Part No.	Pipe Size	Orifice	A	B	C	D1	D2	E	F	G
WSR8P4P	1/2x1/4	.35	2.75	.84	.61	1.50	.75	.35	.54	.83
WSR12P4P	3/4 x 1/4	.35	2.75	1.05	.81	1.50	.75	.35	.54	1.11
WSR12P8P	3/4 x 1/2	.61	3.50	1.05	.81	1.50	1.50	.61	.84	1.11
WSR16P4P	1x1/4	.35	3.50	1.32	1.03	1.50	1.50	.35	.54	1.41
WSR16P8P	1x1/2	.61	3.50	1.32	1.03	1.50	1.50	.61	.84	1.41
WSR16P12P	1x3/4	.81	3.50	1.32	1.03	1.50	1.50	.81	1.05	1.41

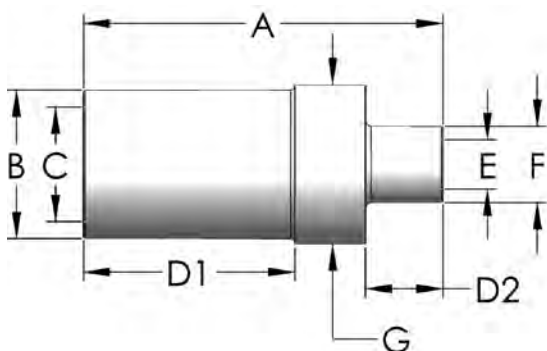

Weld Pipe Cap						
PFA Part No.	Pipe Size	A	B	C	D	E
WCAP4	1/4	.75	.54	.35	.55	.62
WCAP8	1/2	2.00	.84	.61	1.49	.90
WCAP12	3/4	2.01	1.05	.81	1.49	1.11
WCAP16	1	2.01	1.32	1.03	1.49	1.43

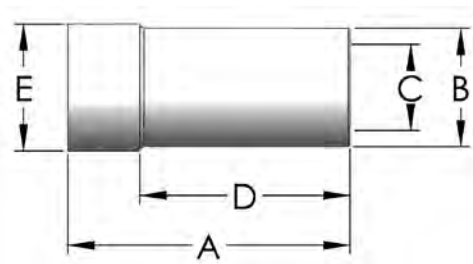

Weld Union Elbow (Pipe x Pipe)					
PFA Part No.	Pipe Size	A	B	C	D
WUE4P	1/4	1.27	.54	.35	.75
WUE8P	1/2	1.47	.84	.61	.75
WUE8PX	1/2	2.22	.84	.61	1.50
WUE12P	3/4	1.55	1.05	.81	.75
WUE12PX	3/4	2.30	1.05	.81	1.50
WUE16P	1	1.50	1.32	1.03	.75
WUE16PX	1	2.18	1.32	1.03	1.48

X = Extended

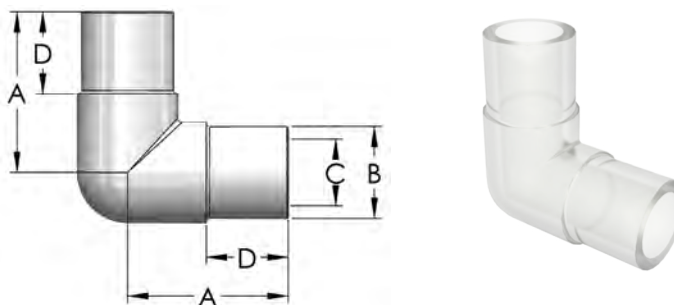

Weld Union Tee (Pipe x Pipe)						
PFA Part No.	Pipe Size	A	B	C	D	E
WUT4P	1/4	2.54	.54	.35	.75	1.27
WUT8P	1/2	2.94	.84	.61	.75	1.47
WUT8PX	1/2	4.44	.84	.61	1.50	2.22
WUT12P	3/4	3.10	1.05	.81	.75	1.55
WUT12PX	3/4	4.60	1.05	.81	1.50	2.30
WUT16P	1	3.00	1.32	1.03	.75	1.50
WUT16PX	1	4.36	1.32	1.03	1.48	2.18

X = Extended

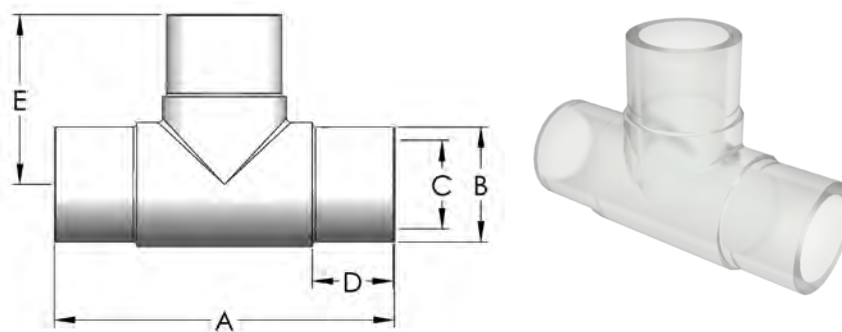

Weld Male Adapter (Pipe x NPT)								
PFA Part No.	Pipe Size	NPT Size	Orifice	A	B	C	D	Hex
WMA4P-4	1/4	1/4	.28	1.39	.54	.35	.55	5/8
WMA8P-6	1/2	3/8	.36	2.56	.84	.61	1.49	1
WMA8P-8	1/2	1/2	.51	2.66	.84	.61	1.49	1
WMA12P-8	3/4	1/2	.51	2.66	.84	.61	1.49	1-3/16
WMA12P-12	3/4	3/4	.66	2.68	1.05	.81	1.49	1-3/16
WMA16P-16	1	1	.94	2.85	1.32	1.03	1.49	1-7/16

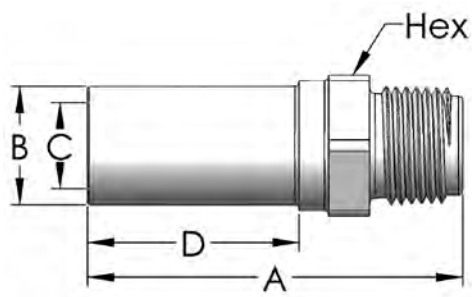

Weld Female Adapter								
PFA Part No.	Pipe Size	NPT Size	Orifice	A	B	C	D	Hex
WFA4P-4	1/4	1/4	.34	1.58	.54	.35	.75	3/4
WFA8P-6	1/2	3/8	.36	2.49	.84	.35	1.49	1
WFA8P-8	1/2	1/2	.51	2.56	.84	.61	1.49	1-3/16
WFA12P-12	3/4	3/4	.79	2.69	1.05	.81	1.49	1-7/16
WFA16P-16	1	1	.99	2.83	1.32	1.03	1.49	1-5/8

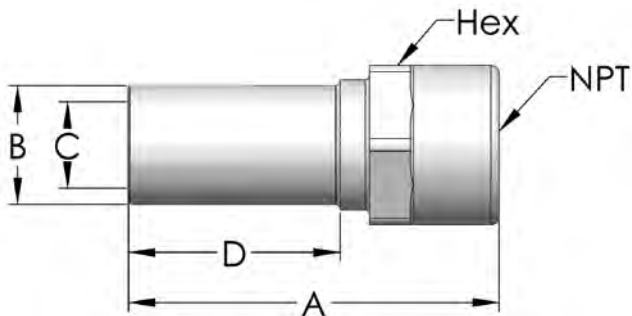

Weld Straight Reducer (Tube x Tube)						
PFA Part No.	Tube OD	A	B	C Orifice	D Orifice	E
WSR6TS4TS	3/8" X 1/4"	1.62	.55	.25	.15	.82
WSR8TS4TS	1/2" X 1/4"	1.62	.55	.38	.15	.82
WSR8TS6TS	1/2" X 3/8"	1.63	.55	.38	.25	.82
WSR12TS4TS	3/4" X 1/4"	1.63	.55	.63	.15	.82
WSR12TS6TS	3/4" X 3/8"	1.63	.55	.63	.25	.82
WSR12TS8TS	3/4" X 1/2"	1.63	.55	.63	.38	.82
WSR16TS4TS	1" X 1/4"	1.63	.55	.88	.15	.82
WSR16TS6TS	1" X 3/8"	1.63	.55	.88	.25	.82
WSR16TS8TS	1" X 1/2"	1.63	.55	.88	.38	.83
WSR16TS12TS	1" X 3/4"	1.54	.55	.88	.63	.74
WSR20TS16TS	1-1/4" X 1"	1.66	.76	1.10	.88	.65

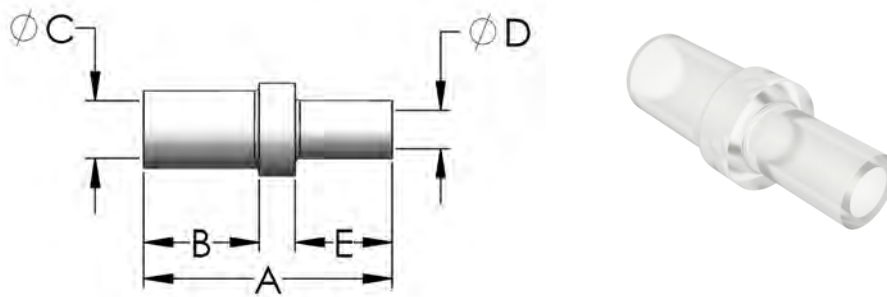

Weld Elbow (Tube x Tube)				
PFA Part No.	Tube OD	A	B	C Orifice
WE4TS	1/4"	1.33	.81	.15
WE6TS	3/8"	1.42	.90	.25
WE8TS	1/2"	1.68	1.16	.38
WE12TS	3/4"	1.87	1.18	.63
WE16TS	1"	2.31	1.36	.88
WE20TS	1-1/4"	2.21	1.26	1.10

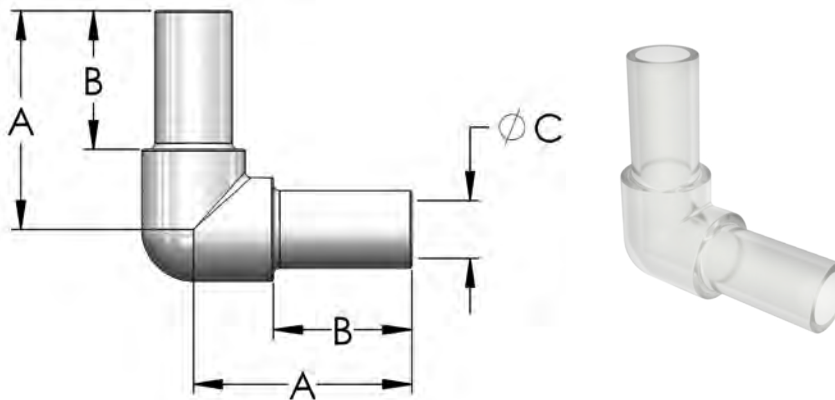

Weld Elbow Reducer (Tube x Tube)							
PFA Part No.	Tube OD	A	B	C Orifice	D Orifice	E	F
WE6TS4TS	3/8" x 1/4"	1.42	.90	.25	.15	1.33	.81
WE8TS4TS	1/2" x 1/4"	1.68	1.16	.38	.15	1.33	.81
WE8TS6TS	1/2" x 3/8"	1.68	1.16	.38	.25	1.42	.90
WE12TS8TS	3/4" x 1/2"	1.87	1.18	.63	.38	1.68	1.16
WE16TS8TS	1" x 1/2"	2.31	1.36	.88	.38	1.68	1.16
WE16TS12TS	1" x 3/4"	2.31	1.36	.88	.63	1.87	1.18

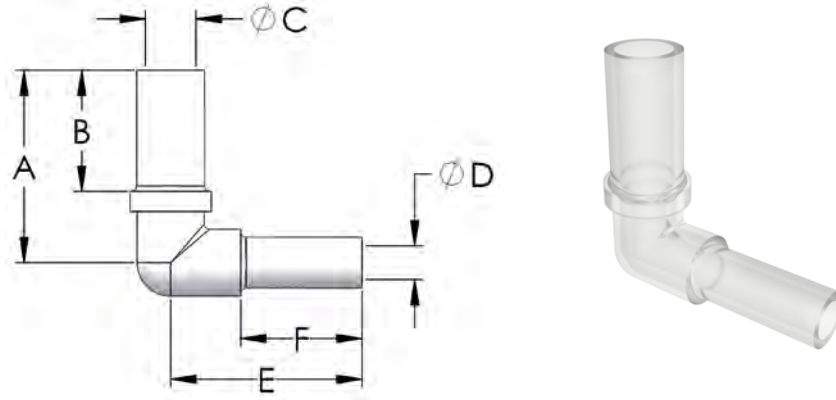

Weld Elbow Sweep (Tube x Tube)				
PFA Part No.	Tube OD	A	B	C Orifice
WES4TS	1/4"	1.41	.60	.15
WES6TS	3/8"	1.61	.70	.25
WES8TS	1/2"	1.79	.80	.38
WES12TS	3/4"	2.17	.92	.63
WES16TS	1"	2.68	.92	.88

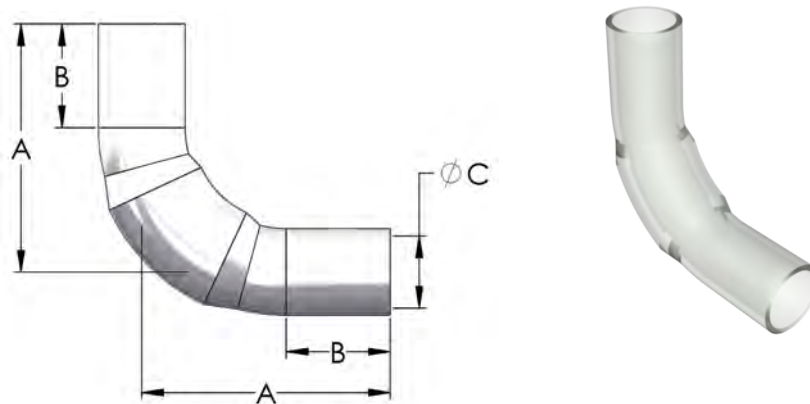



Weld Tee (all Tube)					
PFA Part No.	Tube OD	A	B	C Orifice	D
WT4TS	1/4"	2.66	.81	.15	1.33
WT6TS	3/8"	2.82	.90	.25	1.41
WT8TS	1/2"	3.37	1.16	.38	1.68
WT12TS	3/4"	3.74	1.18	.63	1.87
WT16TS	1"	4.62	1.36	.88	2.31
WT20TS	1-1/4"	4.42	1.26	1.10	2.21

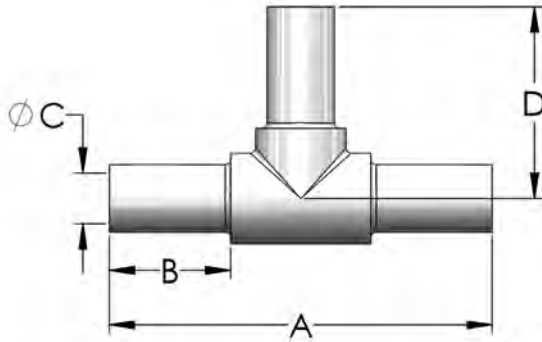

Weld Tee Reducer (all Tube)								
PFA Part No.	"X" OD	"Y" OD	"Z" OD	A	B	C Orifice	D Orifice	E
WT6TS-4TS-6TS	3/8"	1/4"	3/8"	2.82	.90	.25	.15	1.33
WT8TS-4TS-8TS	1/2"	1/4"	1/2"	3.37	1.16	.38	.15	1.33
WT8TS-6TS-8TS	1/2"	3/8"	1/2"	3.37	1.16	.38	.25	1.41
WT12TS-4TS-12TS	3/4"	1/4"	3/4"	3.74	1.18	.63	.15	1.33
WT12TS-6TS-12TS	3/4"	3/8"	3/4"	3.74	1.18	.63	.25	1.41
WT12TS-8TS-12TS	3/4"	1/2"	3/4"	3.74	1.18	.63	.38	1.68
WT16TS-8TS-16TS	1"	1/2"	1"	4.62	1.36	.88	.38	1.68
WT16TS-12TS-16TS	1"	3/4"	1"	4.62	1.36	.88	.63	1.87
WT20TS-16TS-20TS	1-1/4"	1"	1-1/4"	4.42	1.26	1.10	.88	2.31

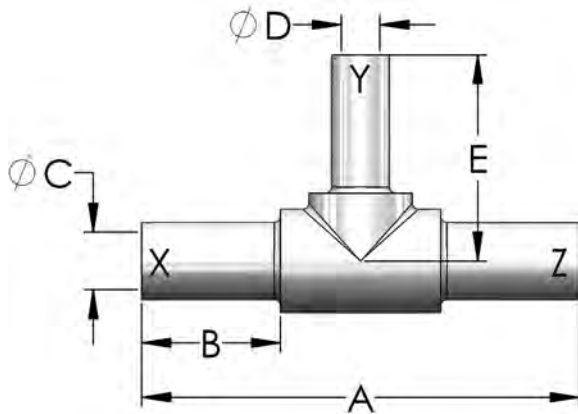

NOTE: Weld Cross and Weld Cross Reducers (all Tube) - refer to Tube Weld Catalog

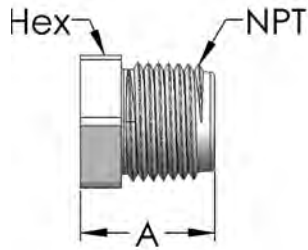

Pipe Plug			
PFA Part No.	NPT Size	A	Hex
PP2	1/8	.80	1/2
PP4	1/4	.85	5/8
PP6	3/8	.85	11/16
PP8	1/2	.96	13/16
PP12	3/4	.96	1-3/16
PP16	1	1.14	1-7/16

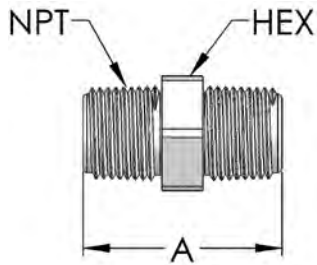

Pipe Nipple			
PFA Part No.	NPT Size	A	Hex
PN2	1/8	1.31	1/2
PN4	1/4	1.41	5/8
PN6	3/8	1.41	11/16
PN8	1/2	1.61	13/16
PN12	3/4	1.67	1-3/16
PN16	1	2.01	1-7/16

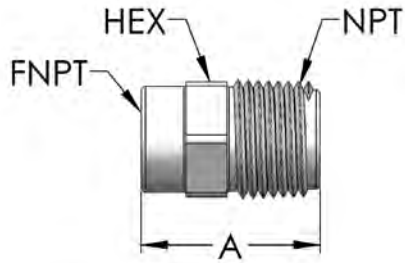

Female Male Connector Reducer				
PFA Part No.	Female NPT	NPT Size	A	Hex
FMCR4-8	1/4	1/2	1.29	13/16
FMCR6-8	3/8	1/2	1.38	15/16
FMCR8-12	1/2	3/4	1.53	1-3/16

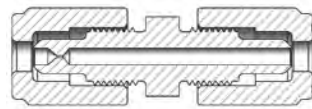
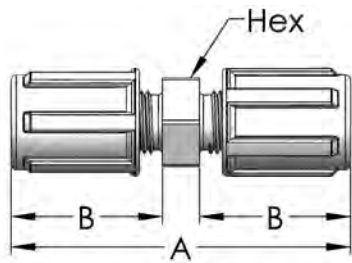

Reduced Orifice Fittings (Straight Union)					
PFA Part No.	Tube O.D.	Orifice	A	B	Hex
SU44N-1x.030	1/4	.030	2.65	1.18	11/16

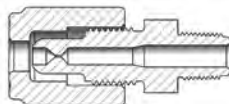
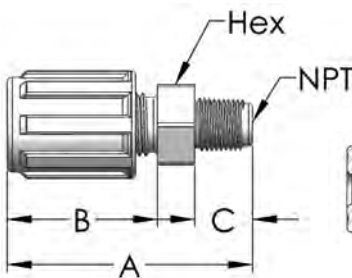

Reduced Orifice Fittings (Male Connector)							
PFA Part No.	Tube O.D.	NPT Size	Orifice	A	B	C	Hex
MC4-2N-1x.030	1/4	1/8	.030	1.92	1.18	.45	5/8
MC4-2N-1x.015	1/4	1/8	.015	1.92	1.18	.45	5/8

Male Connector by Sanitary End							
PVDF Part No.	Tube O.D.	Sanitary Size	Orifice	A	B	C	Hex
MC4-MINI	1/4	MINI	.15	2.49	1.16	1.12	7/8
MC6-MINI	3/8	MINI	.25	2.58	1.25	1.12	7/8
MC8-MINI	1/2	MINI	.38	2.70	1.37	1.12	7/8
MC8-MAXI	1/2	MAXI	.38	2.83	1.37	1.25	1-3/16
MC12-MINI	3/4	MINI	.56	2.72	1.39	1.12	1-1/8
MC12-MAXI	3/4	MAXI	.63	2.99	1.39	1.25	1-3/16
MC16-MINI	1	MINI	.56	2.92	1.59	1.12	1-7/16
MC16-MAXI	1	MAXI	.86	3.04	1.59	1.25	1-7/16

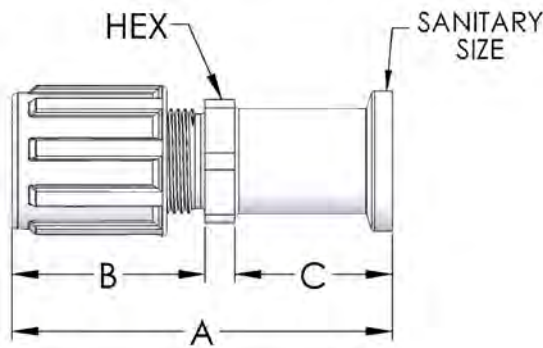

Union Elbow by Sanitary End					
PVDF Part No.	Tube O.D.	Sanitary Size	Orifice	A	B
UE12-MINI	3/4	MINI	.56	2.22	1.63
UE12-MAXI	3/4	MAXI	.63	2.22	1.95
UE16-MINI	1	MINI	.56	2.71	1.63
UE16-MAXI	1	MAXI	.86	2.71	1.95

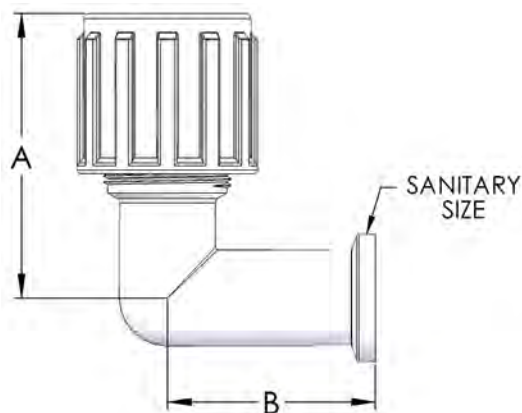

Multi-Flare Panel Mount										
U.S. Patent 5,833,278										
PVDF Part No.	Tube O.D.	Ports	Orifice	A	B	C	D (Max)	Hex 1	Hex 2	Minimum Panel Hole Diameter
MSUPM4-2	1/4	2	.15	4.13	1.60	2.30	.50	1-3/8	1-1/4	1-1/8
MSUPM4-3	1/4	3	.15	4.13	1.60	2.30	.50	1-3/8	1-1/4	1-1/8
MSUPM4-4	1/4	4	.15	4.13	1.60	2.30	.50	1-1/2	1-3/8	1-1/4
MSUPM4-6	1/4	6	.15	4.13	1.60	2.30	.50	1-3/4	1-5/8	1-1/2

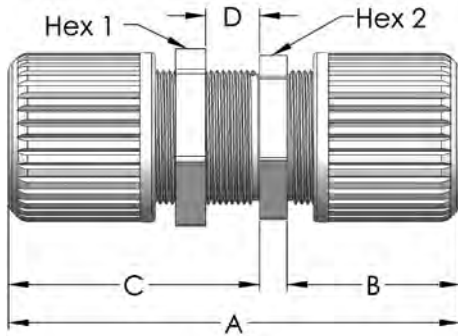

Multi-Flare Male Connector									
U.S. Patent 5,833,278									
PVDF Part No.	Tube O.D.	NPT Size	Ports	Orifice	A	B	C	Hex	
MMC4-8-2	1/4	1/2	2	.15	2.49	1.60	.66	1-1/4	
MMC4-8-3	1/4	1/2	3	.15	2.49	1.60	.66	1-1/4	
MMC4-12-2	1/4	3/4	2	.15	2.50	1.60	.67	1-1/4	
MMC4-12-3	1/4	3/4	3	.15	2.50	1.60	.67	1-1/4	
MMC4-12-4	1/4	3/4	4	.15	2.50	1.60	.67	1-3/8	
MMC4-16-3	1/4	1	3	.15	2.68	1.60	.85	1-1/4	
MMC4-16-4	1/4	1	4	.15	2.68	1.60	.85	1-3/8	
MMC4-16-6	1/4	1	6	.15	2.68	1.60	.85	1-5/8	

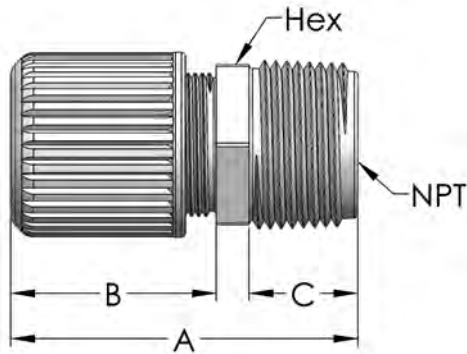

Multi-Flare Transition Fitting								
U.S. Patent 5,833,278								
PVDF Part No.	Tube O.D.	Ports	Orifice	A	B	C	D	Hex
MTSF4-20MM-2	1/4	2	.15	3.75	.79	.64	1.50	1-1/4
MTSF4-20MM-3	1/4	3	.15	3.75	.79	.64	1.50	1-1/4
MTSF4-25MM-2	1/4	2	.15	3.75	.98	.82	1.50	1-1/4
MTSF4-25MM-3	1/4	3	.15	3.75	.98	.82	1.50	1-1/4
MTSF4-25MM-4	1/4	4	.15	3.75	.98	.82	1.50	1-3/8
MTSF4-32MM-3	1/4	3	.15	3.75	1.26	1.07	1.50	1-1/4
MTSF4-32MM-4	1/4	4	.15	3.75	1.26	1.07	1.50	1-3/8
MTSF4-32MM-6	1/4	6	.15	3.75	1.26	1.07	1.50	1-5/8

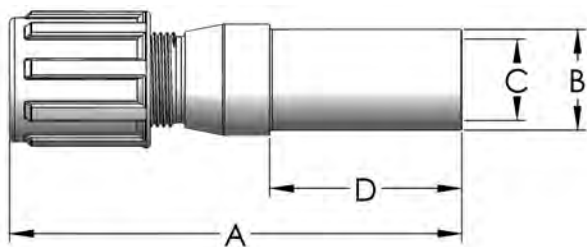
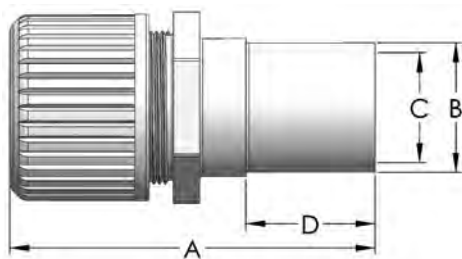

Transition Fitting					
(Male Flare x Metric Pipe)					
PVDF Part No.	Tube O.D.	A	B	C	D
TSF4-20MM	1/4	3.30	.79	.64	1.50
TSF4-25MM	1/4	3.30	.98	.82	1.50
TSF6-20MM	3/8	3.40	.79	.64	1.50
TSF6-25MM	3/8	3.40	.98	.82	1.50
TSF8-20MM	1/2	3.50	.79	.64	1.50
TSF8-25MM	1/2	3.50	.98	.82	1.50
TSF8-32MM	1/2	3.50	1.26	1.07	1.50
TSF8-40MM	1/2	3.50	1.57	1.38	1.50
TSF12-20MM	3/4	3.64	.79	.64	1.50
TSF12-25MM	3/4	3.64	.98	.82	1.50
TSF12-32MM	3/4	3.64	1.26	1.07	1.50
TSF12-40MM	3/4	3.64	1.57	1.38	1.50
TSF16-25MM	1	3.80	.98	.82	1.50
TSF16-32MM	1	3.80	1.26	1.07	1.50
TSF16-40MM	1	3.80	1.57	1.38	1.50
TSF16-50MM	1	3.90	1.97	1.73	1.48
TSF16-63MM	1	3.90	2.48	2.24	1.48
TSF20-40MM	1-1/4	4.16	1.57	1.38	1.50
TSF20-50MM	1-1/4	4.16	1.97	1.73	1.48
TSF20-63MM	1-1/4	4.16	2.48	2.24	1.48



# TruFLARE™ Tube Flaring System Procedures

1. Turn on the machine and set temperature to 280°C. Activate the ram forward to the "START" position.
2. Cut the tube end as square as possible. Then insert the tube end through the backside of the nut.
3. Insert the tube end into the appropriate heater port as deep as possible. The "HEAT TIME" cycle will start. Remove when the "Alarm Sound" begins.
4. Insert the heated tube end into the mating port size on the clamping blocks. Slide the tube end up to the 45° chamfer.
5. Activate the vertical clamp block to a locking position.
6. Move the ram forward in a smooth and even motion to a locking position to activate the "CURE TIME" cycle. Retract the ram fully after the "Alarm Sound" begins.
7. Unlock the vertical ram and remove the flared tube end.

Patented TruFLARE™ Tube Flaring System creates a standard tube flare end by pressure forming and rapidly cooling the flare form. The TruFLARE™ system is ideal for production flaring and assures precise, concentric, repeatable tube flare connections. All without requiring immediate assembly, which is often the case with other rudimentary hot flaring components.

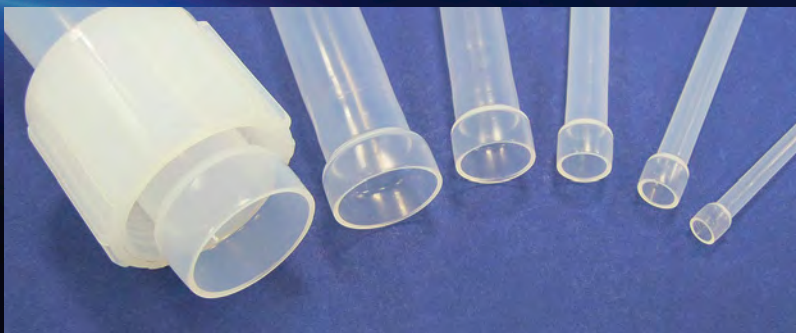
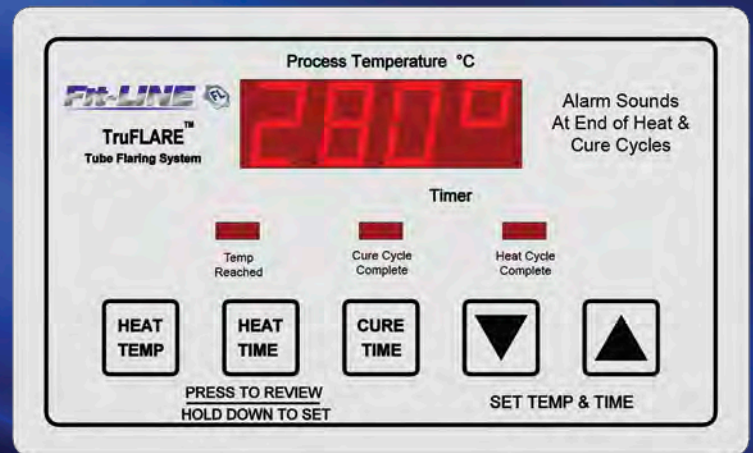
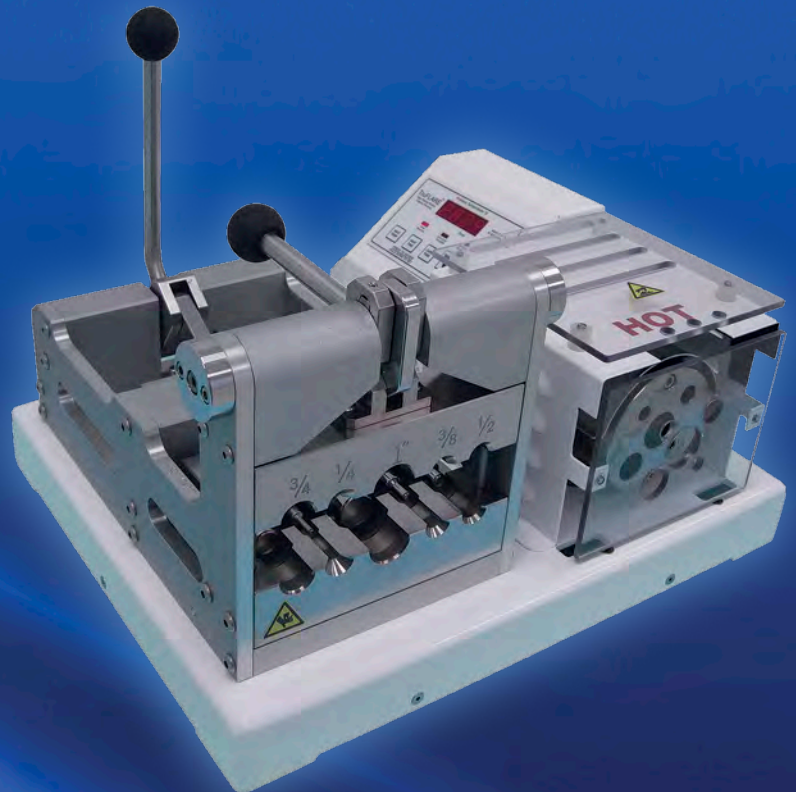

Part No.	Description
TF 416-110	1/4" through 1" Tubing x 110V
TF 416-220	1/4" through 1" Tubing x 220V
TF 20-110	1-1/4" Tubing x 110V
TF 20-220	1-1/4" Tubing x 220V



# Installation and Assembly Procedures

## Assembly Procedures

1. Cut the tube evenly with a tube cutter and insert through the non-threaded side of the nut.
2. Insert FlareLINK™ tool into the tube all the way to the shoulder of the tool.
3. Apply light pressure to the tube while holding it to the tool.
4. Expand tool 10 to 20%.
5. Relax pressure and rotate the tube, then reapply pressure.
6. Repeat steps 4 and 5 progressively increasing the pressure until the tool is completely expanded.
7. Insert the tube onto the FlareLINK™ fitting and tighten nut onto the fitting.

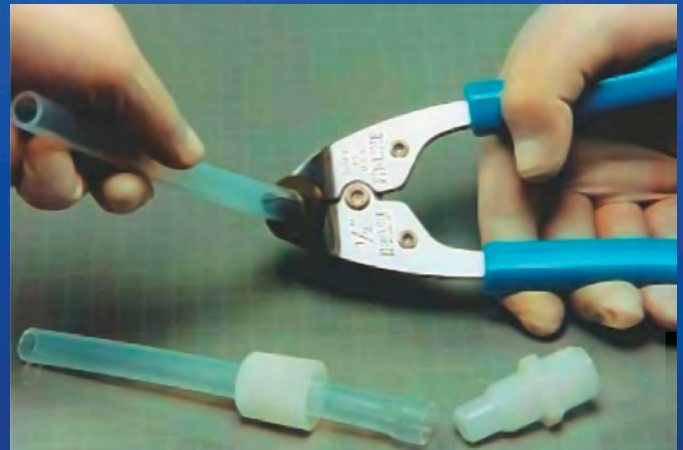

Using the manual flaring method is the fastest, easiest installation system available today, taking just 10 to 20 seconds to install a tube-to-fitting connection using a simple hand tool. No heating or preparation is necessary. This simple method alone can save up to 70 percent of the installation cost.



Recommended Nut Torque Setting			
Tubing Size	Wall Size	Minimum Torque (in-lb)	Maximum Torque (in-lb)
1/4	.030	6	10
1/4	.047	6	11
3/8	.030	7	10
3/8	.062	9	18
1/2	.062	12	23
3/4	.062	20	30
1	.062	30	48
1-1/4	.075	60	80

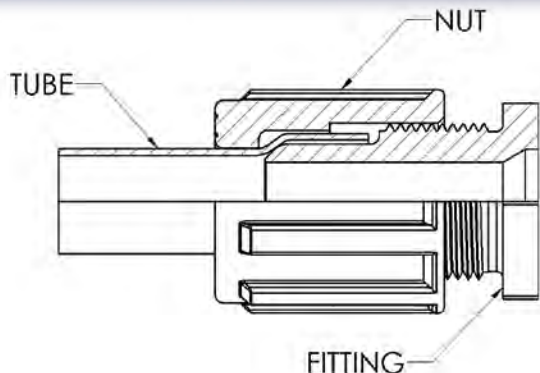

Tube O.D.	Part No.
1/4	FT-4
3/8	FT-6
1/2	FT-8
3/4	FT-12
1	FT-16

Manual Tube Flaring Tools  
U.S. Patent 5,382,151

# Welded Systems

## Fabricated Manifolds

Custom Welded Manifolds fabricated in 72hrs or less

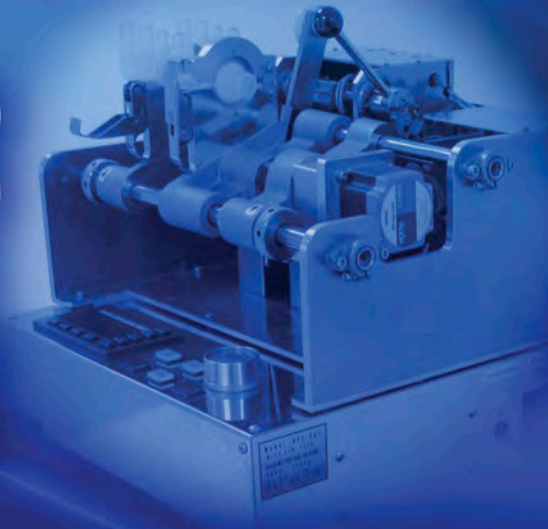
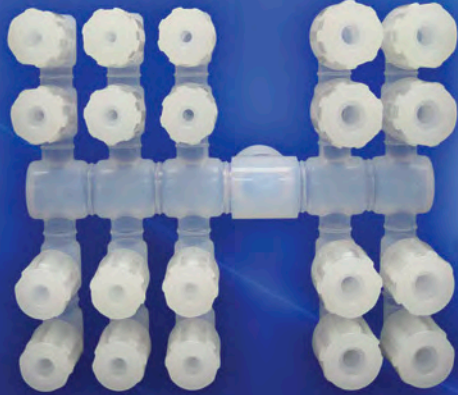





## Warranty

Fit-LINE warrants its products against defects in material or workmanship for a period of one year from the date of shipment to the buyer. Adjustments under this warranty will be made only after complete inspection and confirmation of defects by Fit-LINE. Liability under the warranty shall extend only to the replacement or correction of the product not conforming to the warranty as determined by Fit-LINE. All materials must be returned freight prepaid.

This warranty shall not apply to any product that has been repaired or altered by the customer without the manufacturer's knowledge and consent. This warranty shall not apply to products which have been subjected to misuse, improper maintenance, or damage through accident or negligence.

No other warranty, written or oral, is authorized by Fit-LINE. No responsibility is assumed for any special, incidental, or consequential damages. Implied warranties of merchantability and fitness for a particular purpose are specifically disclaimed.

### **Fit-LINE, Inc.**

2901 Tech Center Drive

Santa Ana, CA 92705

Phone: (714) 549-9091

Fax: (714) 549-2778

[www.fitlineinc.com](http://www.fitlineinc.com)

Copyright 2012 Fit-LINE, Inc.

Printed in USA

# Fit-LINE

## TruFLARE™ Tube Flaring System

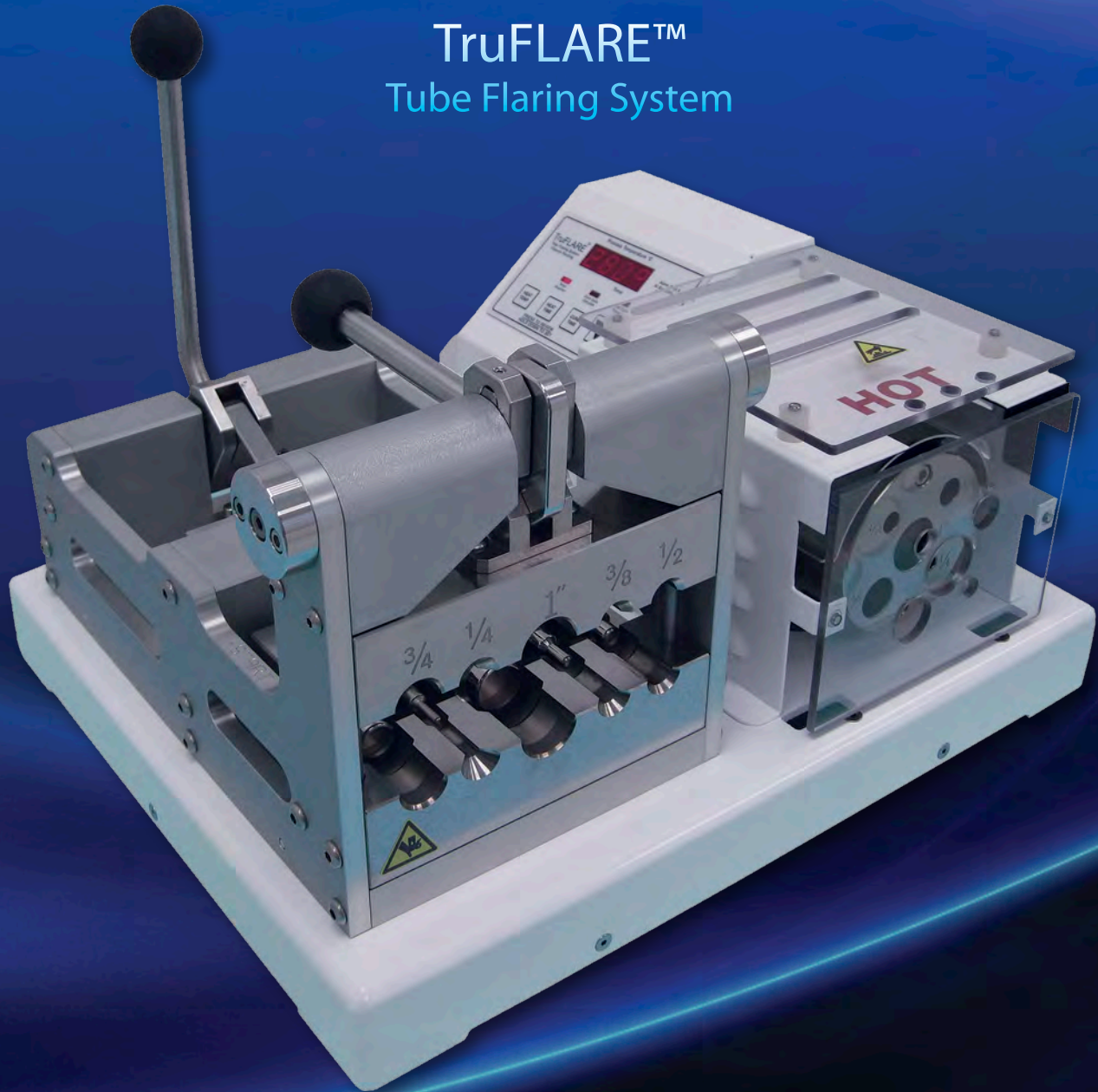

Fit-LINE, Inc. | 2901 Tech Center Drive, Santa Ana, CA 92705  
Phone: (714) 549-9091 | Fax: (714) 549-2778 | [www.fitlineinc.com](http://www.fitlineinc.com)

Copyright 2012 Fit-LINE, Inc. | Printed in USA