



**FINISH THOMPSON INC.**

## **EF SERIES MOTORS OPERATION & PARTS MANUAL**

**Models S1, S2, S3, S4**



S1, S2, S3



S4



**FINISH THOMPSON INC.**  
921 Greengarden Road • Erie, PA 16501-1591 U.S.A.  
Ph 814-455-4478 • Fax 814-455-8518  
Email [fti@finishthompson.com](mailto:fti@finishthompson.com) • [www.finishthompson.com](http://www.finishthompson.com)

## EU Declaration of Conformity



Finish Thompson Inc. hereby declares that the following electrical equipment fully complies with the applicable health and safety requirements as specified by the EU directives listed. The product may not be taken into service until it has been established that the driven Drum and Container Pump complies with the provisions of all relevant EU Directives provided pumps manufactured by Finish Thompson are used.

This declaration is valid provided that the devices are fully assembled and no modifications are made to these devices.

### Type of Device:

Electric Motors for Driving Drum  
and Container Pumps

### Models:

M3V-UK    M5    M5T    M5V    M5X    M10X  
M13    M59P    M59H    S2    S3

### EU Directives (and their applicable amendments):

Low Voltage (2014/35/EU)  
Electromagnetic Compatibility (2014/30/EU)

### Specific standards applied:

EN 60335-1    EN60335-2-41  
EN 55014-1    EN 55014-2  
EN 60529

Signed,

---

Casey D. Bowes  
CEO and President

20 April 2016

Person(s) Authorized to Compile Technical File: Finish Thompson GmbH  
Otto-Hahn-Strasse 16  
Maintal, D-63477 DEU  
Telephone: 49 (0)6181-90878-0



**FINISH THOMPSON INC.**

921 Greengarden Road • Erie, PA 16501-1591 U.S.A.

Ph 814-455-4478 • Fax 814-455-8518

Email [fti@finishthompson.com](mailto:fti@finishthompson.com) • [www.finishthompson.com](http://www.finishthompson.com)

## EU Declaration of Conformity



Finish Thompson Inc. hereby declares that the following machine(s) fully comply with the applicable health and safety requirements as specified by the EU Directives listed. The product may not be taken into service until it has been established that the driven Drum and Container pump complies with the provisions of all relevant EU Directives. The complete product complies with the provisions of the EU Directive on machinery safety provided pumps manufactured by Finish Thompson Inc. are used.

This declaration is valid provided that the devices are fully assembled and no modifications are made to these devices.

### Type of Device:

Air Motors for Driving Drum and Container Pumps

### Models:

M6	M6X	M18	M19	M20	M57
	M65	M66	S4	S4A	

### EU Directives:

Machinery Safety (2006/42/EC)

### Applied Harmonized Standards:

EN ISO 12100

EN 983

### Manufacturer:

Finish Thompson Inc.  
921 Greengarden Road  
Erie, Pennsylvania 16501-1591 U.S.A

Signed,

  
\_\_\_\_\_  
President

1 August 2016

Person(s) Authorized to Compile Technical File: Finish Thompson GmbH  
Otto-Hahn-Strasse 16  
Maintal, D-63477 DEU  
Telephone: 49 (0)6181-90878-0

## Introduction

This manual pertains to S Series drum pump motors. Finish Thompson Inc. thanks you for choosing our products. We believe that the use of our products will be fully satisfactory. When properly installed and operated, your Finish Thompson motor and pump will provide long, trouble-free service; therefore, please read this manual carefully before carrying out any operations on the pump/motor unit. Any use other than that described herein is considered incorrect; consequently, Finish Thompson Inc. shall not be held responsible for any damages to people or things. In case of doubt or enquiries, please apply to our Technical Service department directly at the following address:

Finish Thompson, Inc.  
921 Greengarden Rd.  
Erie, PA 16501 U.S.A.  
Tel. 1-814-455-4478  
Fax 1-814-455-8518  
[www.finishthompson.com](http://www.finishthompson.com)  
[fti@finishthompson.com](mailto:fti@finishthompson.com)

## Index

Introduction . . . . .	1
Warranty, General Terms & Conditions . . . . .	2
Safety . . . . .	3
Installation . . . . .	4
Operation . . . . .	5
Specifications, Identification, Performance . . . . .	6
Electric Motor Spare Parts . . . . .	7
Air Motor Spare Parts . . . . .	8

## Warranty, General Terms & Conditions

1. The following terms and conditions apply to the sale of machinery, components and related services and products, of Finish Thompson Inc. (hereinafter “the products”)
2. Finish Thompson Inc. (the manufacturer) warrants only that:
  - a) its products are free of defects in material, design and workmanship at the time of original purchase;
  - b) its products will function in accordance with Finish Thompson Inc. operation manuals; Finish Thompson Inc. does not guarantee that the product will meet the precise needs of the Customer, except for those purposes set out in any invitation to render documents or other documents specifically made available to Finish Thompson Inc. before entering into this agreement;
  - c) high quality materials are used in the construction of the motors and that machining and assembly are carried out to the highest standards. Except as expressly stated above, Finish Thompson Inc. makes no warranties, express or implied, concerning the products, including all warranties of fitness for a particular purpose.

This warranty shall not be applicable in circumstances other than defects in material, design, and workmanship. In particular warranty shall not cover the following:

- d) Periodic checks, maintenance, repair and replacement of parts due to normal wear and tear;
- e) Damage to the product resulting from:
  - i. Tampering with, abuse or misuse, including but not limited to failure to use the product for its normal purposes as stated at the time of purchase or in accordance with Finish Thompson Inc. instructions for use and maintenance of the product, or the installation or improper ventilation or use of the product in a manner inconsistent with the technical or safety standard in force;
  - ii. Repairs performed by non-authorized service workshop, or opening of the unit by non-authorized personnel, or use of non genuine Finish Thompson Inc. parts;
  - iii. Accidents, force majeure or any cause beyond the control of Finish Thompson Inc., including but not limited to lightning, water, fire, earthquake, and public disturbances, etc.
3. The warranty shall cover the replacement or repair of any part, which is documented to be faulty due to construction or assembling, with new or repaired parts free of charge delivered by Finish Thompson, Inc. Parts subjected to normal wear and tear shall not be covered by the warranty. Finish Thompson Inc. shall decide as to whether the defective or faulty part shall be replaced or repaired. Transportation charges are prepaid to Finish Thompson.
4. The warranty of the products shall be valid for a period of **12 months** from the date of delivery, under the condition that notice of the alleged defect to the products or parts thereof be given to Finish Thompson, Inc. within the term of 8 days from the discovery.
5. Repair or replacement under the terms of this warranty shall not give a right to an extension to, or a new commencement of, the period of warranty. Repair or replacement under the terms of this warranty may be fulfilled with functionally equivalent re-conditioned units. Finish Thompson Inc. qualified personnel shall be solely entitled to carry out repair or replacement of faulty parts after careful examination of the motor. Faulty parts or components when replaced by Finish Thompson Inc. will become the property of Finish Thompson Inc. If this warranty does not apply, the purchaser shall bear all cost for labor, material and transportation.
6. Finish Thompson Inc. will not be liable on any claim, whether in contract, tort, or otherwise, for any indirect, special, incidental, or consequential damages, caused to the customer or to third parties, including loss of profits, process down time, transportation costs, costs associated with replacement or substitution products, labor costs, installation or removal costs. In any and all events, manufacturer’s liability shall not exceed the purchase price of the product and/or accessories.
7. **Return Policy.** Should you have any problems with this product, please contact the distributor in your area. The distributor will determine if a return to the factory is necessary and will contact the factory for a Return Authorization Number. Otherwise, contact our Technical Service Hotline (1-800-888-3743) or email [techservice@finishthompson.com](mailto:techservice@finishthompson.com) if you have any questions regarding product operation or repair.

## Safety

### 1. Introduction

This manual contains all the information needed for the correct installation, use and maintenance of your new Finish Thompson motor. It should be read and understood by all the personnel involved in installation, operating and servicing of the pump before it is started.

### 2. Operator Qualification and Training

The personnel in charge of the installation, the operation and maintenance of the pump/motor must be qualified and able to perform the operations described in this manual. Finish Thompson Inc. shall not be held responsible for the training level of personnel and for the fact that they are not fully aware of the contents of this manual.

### 3. Safety Instructions

#### **FOR YOUR OWN SAFETY**

BEFORE using or servicing your pump, please make sure to wear the proper clothing, eye protection and follow standard safety procedures when handling corrosive or personally harmful materials.

#### **GENERAL DANGER**

**NEVER** use a plastic pump or an open, splash-proof, TEFC or non-ATEX motor when pumping or mixing flammable or combustible material.

**ALWAYS** use a Model EFS 316SS pump tube with Model S4 air motor and static protection kit with grounded discharge hose, P/N 107429, when pumping or mixing flammable or combustible material. Follow Assembly, Installation & Operating Instructions from manual, P/N J102721, included with the static protection kit or it can be accessed online at [www.finishthompson.com/downloads](http://www.finishthompson.com/downloads).

**ALWAYS** use and store the pump and motor in an upright position.

#### **DANGER: POWER SUPPLY**

**NEVER** perform any maintenance operation on the motor while it is running or before it has been disconnected from the power supply. Avoid any possible hazard that might be caused by electric power.

**ALWAYS** check the electrical specifications on the motor data plate and make sure they correspond to the power supply to which it will be connected.

**ALWAYS** place motor in the OFF position prior to connecting the power source.

**NEVER** immerse the motor in liquid.

### 4. Noise Level

S1, S2, and S3 electric motors in normal operating conditions produce a sound level equal to or less than 74 dBA at a distance of three feet (~ one meter). S4 Air motor produces a sound level equal to or less than 78 dBA at a distance of three feet (~ one meter)

### 5. Modifications and Spare Parts

Any changes concerning the service of the motor/pump as originally purchased can be executed only after written approval from Finish Thompson Inc. It is recommended to use only genuine Finish Thompson Inc. spare parts and approved accessories. The use of non-original spare parts or non-approved accessories will void warranty and remove any responsibility on the manufacturer's behalf for any damage caused to people or things.

## INSTALLATION

1. Unpack motor and pump tube from carton. Check for shipping damage. If damage is detected, save the packaging and notify the carrier immediately.
2. If motor and pump tube are boxed separately, the motor will need to be fastened to the pump tube. See figures 1 & 2.



Figure 1



Figure 2

3. Place the motor upside down on a tabletop surface with the coupling facing upwards and place the yellow coupling insert (item 1 from the pump manual) onto the motor's coupling. See figures 3 & 4.



Figure 3



Figure 4

4. Position the pump tube upside down onto the motor. For electric motors, align the discharge spout of the pump facing away from the handle of the motor. See figure 5. For air motors, the ball valve & muffler should be aligned with the discharge spout for ease of operation. See figure 6.



Figure 5



Figure 6

5. Firmly press the pump tube onto the motor until it is fully seated. A slight twist may be necessary for the coupling splines to line up properly.
6. Align the 4 bolt holes in the pump to the 4 holes in the motor, and fasten with 4 flat washers (item 7) and 4 screws (item 8). Tighten using a # 2 Phillips head screwdriver. See figures 7 & 8. **[Note: The EFS (316SS) model does not use the 4 flat washers. Hand-tighten, being careful not to over-torque and strip the plastic.]**

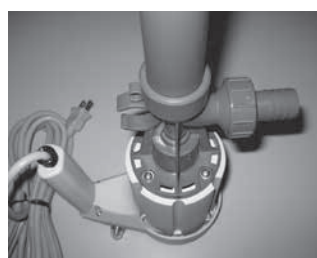

Figure 7



Figure 8

7. Using a SS hose clamp, secure a 3/4" ID chemically compatible reinforced hose to the discharge spout of the pump.

## OPERATION

**Electric motor** - Check that the motor switch is in the center "0" OFF position, and then plug the power cord into an outlet. Insert the pump tube into the fluid to be dispensed and the discharge hose into the container to be filled. While holding the motor handle and hose, switch the motor to the "I" low speed. The fluid will begin to pump. If more flow is desired, switch the motor to the "II" high speed setting. See figure 9 below. If the motor stops working and the reset button has popped out, press the switch to the off position "0". Review your application to make sure it is within the capabilities of the pump (reset button pops typically from an overloading situation). Allow the motor to cool down for at least 30 minutes and then press in the reset button located on the side of the motor handle. See figure 9.

**Air motor** – Turn the air motor ball valve to the closed position. Attach the air motor to an air supply line filtered, lubricated (use detergent SAE #10 oil) and regulated to 40 psi and 27 CFM using a ¼" FNPT fitting. (Note: Finish Thompson offers an optional Filter / Lubricator, P/N A100003.) Insert the pump tube into the fluid to be dispensed and the hose in the container to be filled. While holding the air motor ball valve and hose, slowly turn the valve to the desired flow rate. (Note: Pump performance will vary depending on air pressure & volume.) See figure 10 below.



Figure 9

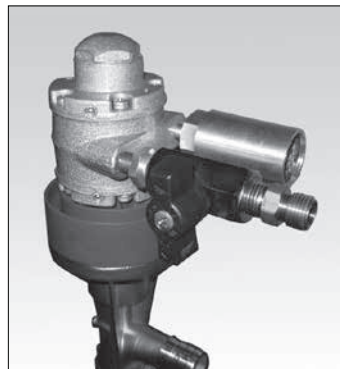

Figure 10

**Pump** – The EFP & EFV model pumps have a built in hose & cord clip. You can use these clips to store your hose and keep the plug off the floor free of damage & corrosion. When selecting a discharge hose you should use a ¾" ID reinforced chemically compatible hose secured with a SS hose clamp. See figures 11 & 12 below.







Figure 11



Figure 12



**MOTOR SPECIFICATIONS**

SPECIFICATIONS	ELECTRIC MOTORS (2 SPEED)			AIR MOTOR
	MODEL S1	MODEL S2	MODEL S3	MODEL S4
Nominal Voltage	115 Volts	230 Volts	115 Volts	N/A
Hertz	60	50/60	50/60	N/A
Rated Amps	2.0 Amps	1.1 Amps	2.0 Amps	N/A
Input Power	1/3 HP (230 Watts)	250 Watts	230 Watts	1/2 HP
Duty Cycle	Continuous	Continuous	Continuous	Continuous
RPM (low / high speed)	8,000 / 14,000	8,000 / 14,000	8,000 / 14,000	300 - 11,000
Max. Flow	17.0 GPM (64 l/m)	17.0 GPM (64 l/m)	17.0 GPM (64 l/m)	15.0 GPM (57 l/m)
Max. Head	20 Ft. (6M)	20 Ft. (6M)	20 Ft. (6M)	17 Ft. (5.2M)
Max. Air Pressure / CFM	N/A	N/A	N/A	40 psi / 27 CFM
Enclosure	Double Insulated, ENC 3 Splash-Proof	Double Insulated, IP24 Splash-Proof	Double Insulated, IP24 Splash-Proof	N/A
Certificates or Approvals				

**ELECTRIC MOTOR IDENTIFICATION  
(S1 Sample Label)**



**AIR MOTOR IDENTIFICATION  
(S4 Sample Label)**



**EF Performance with Electric and Air Motors**

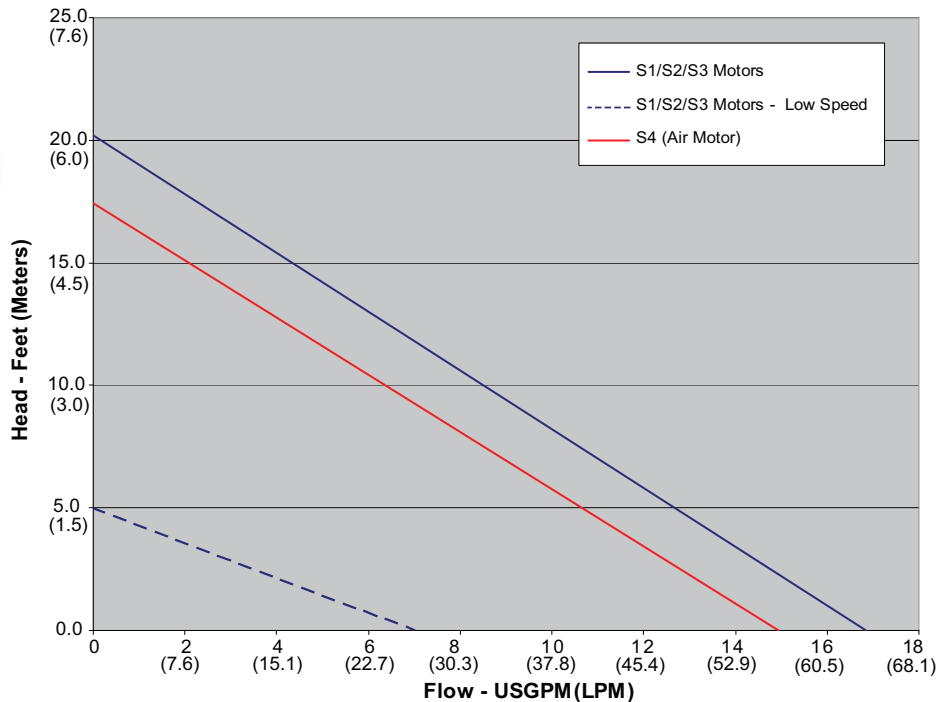

Viscosity	100 cP		200 cP		300 cP	
Max. Flow	7 gpm	27 lpm	5 gpm	19 lpm	3.7 gpm	14 lpm
Max. Head	16 feet (4.9 m)					

Note: All testing was performed with water at 68°F. Actual performance can vary by +/- 10%. Actual performance will decrease with increased fluid viscosity and specific gravity. Viscosity and performance are based on electric motor at high speed.

**PARTS LIST – ELECTRIC MOTORS**  
**Models S1, S2 & S3**

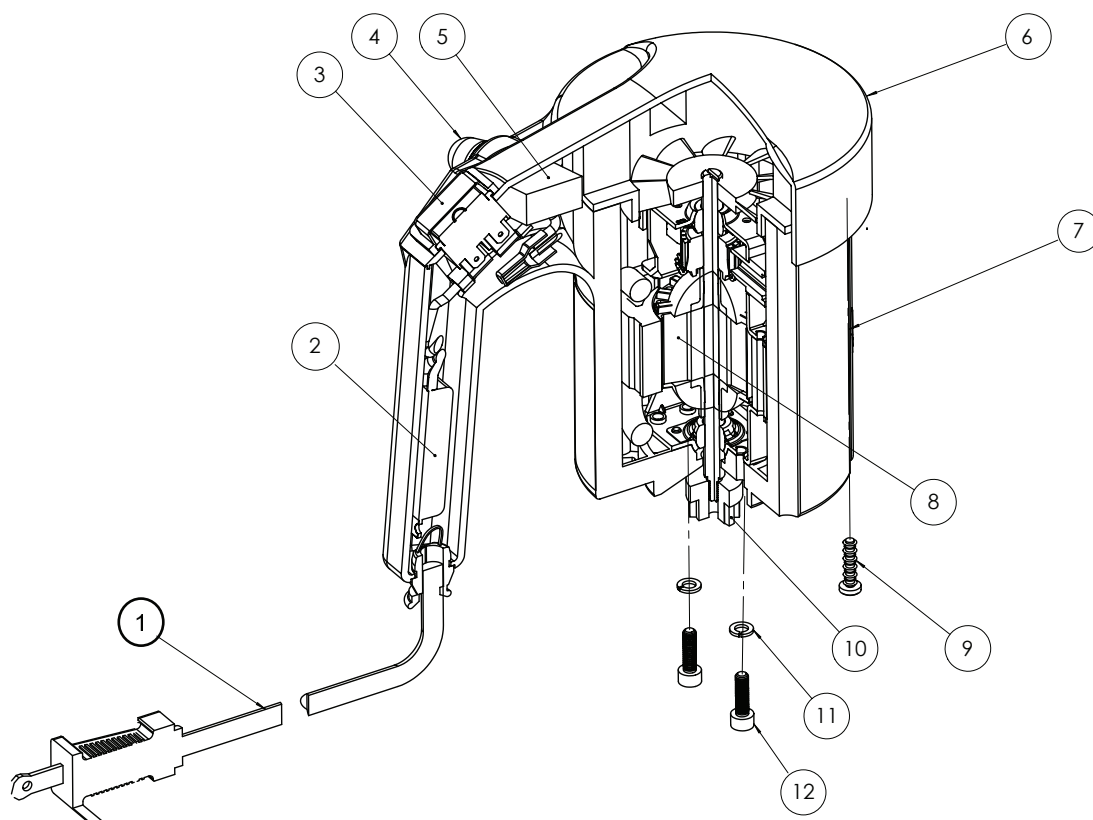

ITEM	QTY	DESCRIPTION	PART NUMBER		
			MODEL S1	MODEL S2	MODEL S3
1	1	115V US CORD	107215	N/A	N/A
		230V EU CORD	N/A	107216	N/A
		115V UK CORD	N/A	N/A	107216-1
2	1	TRIAC ASSEMBLY - 115V	107265-1	N/A	107265-1
		TRIAC ASSEMBLY - 230V	N/A	107265-2	N/A
3	1	ON/OFF SWITCH	107304	107304	107304
4	1	CIRCUIT BREAKER COVER	J100789	J100789	J100789
5	1	CIRCUIT BREAKER - 115v	107326	N/A	107326
		CIRCUIT BREAKER - 230v	N/A	107327	N/A
6	1	MOTOR COVER	107065	107065	107065
7	1	MOTOR CANISTER	107066	107066	107066
8	1	MOTOR - 115V	107301	N/A	107301
		MOTOR - 230V	N/A	107302	N/A
9	6	HI-LOW SCREW - SS	J101020	J101020	J101020
10	1	COUPLING HALF	107300	107300	107300
11	2	LOCK WASHER - SS	106322	106322	106322
12	2	SOCKET HEAD CAP SCREW - SS	107303	107303	107303
N/S	1	COUPLING INSERT	J103422	J103422	J103422
N/S - Not Shown			N/A - Not Applicable		

**PARTS LIST - AIR MOTOR  
Model S4**

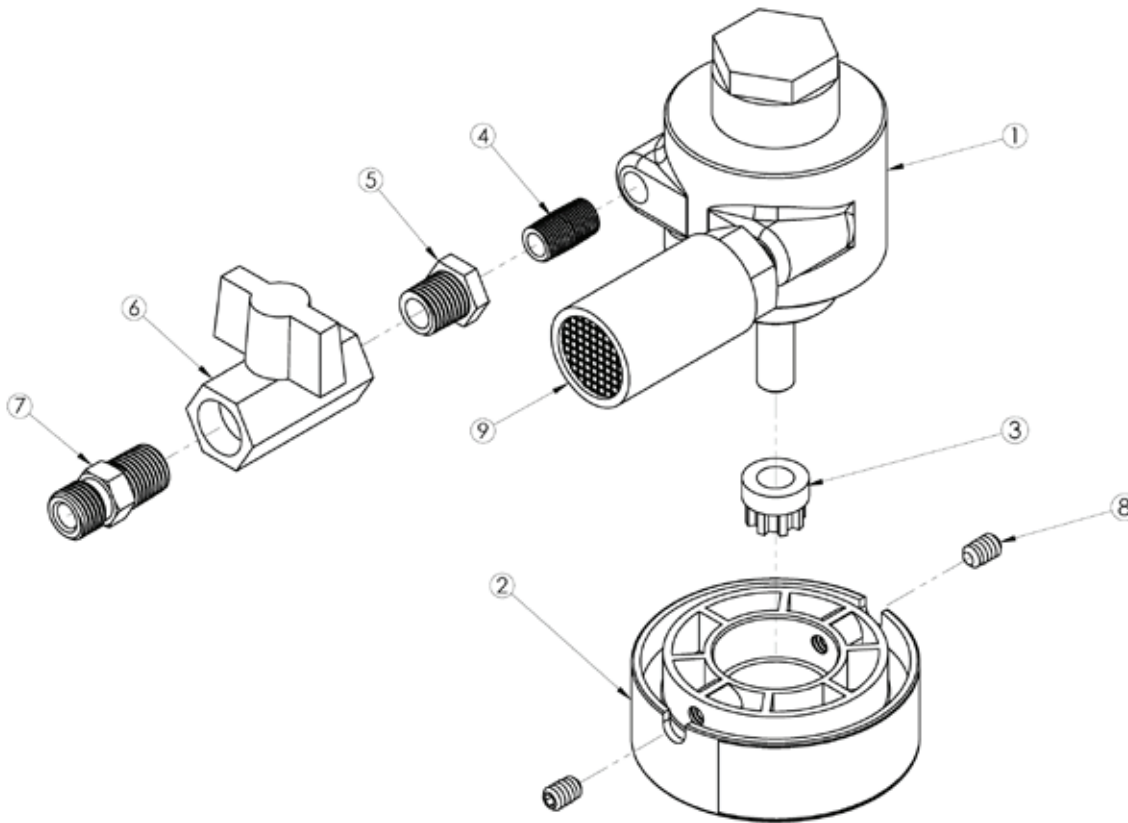

MODEL S4 PARTS LIST			
ITEM	QTY	DESCRIPTION	PART NO.
1	1	AIR MOTOR ONLY	J100032
2	1	AIR MOTOR ADAPTER	107073
3	1	COUPLING HALF	J103934
4	1	NIPPLE	J100107
5	1	HEX REDUCER BUSHING	J100057
6	1	BALL VALVE	J100073
7	1	UNION - BRASS	J100036
8	2	SET SCREW	J100040
9	1	MUFFLER	J100033
N/S	1	AIR MOTOR REPAIR KIT	J100060
N/S	1	OPTIONAL - FILTER / LUBRICATOR	A100003
N/S	1	COUPLING INSERT	J103422
N/S - NOT SHOWN			



**FINISH THOMPSON INC.**

921 Greengarden Road • Erie, PA 16501-1591 U.S.A.  
Ph 814-455-4478 • Fax 814-455-8518  
Email [fti@finishthompson.com](mailto:fti@finishthompson.com) • [www.finishthompson.com](http://www.finishthompson.com)

Tech Service 1-800-888-3743  
[techservice@finishthompson.com](mailto:techservice@finishthompson.com)  
Literature ID No. FT09- 1103  
P/N 107318 Rev 2, 4/20/2016