

Pressure Retaining Valve Type 586



General

- **Size:** 3/8"–2"
- **Material:** PVC, CPVC, PROGEF® Standard PP, SYGEF® Standard PVDF
- **Bonnet:** Glass-filled PP
- **Diaphragm:** PTFE/EPDM
- **Seals:** EPDM, FPM, PTFE
- **End Connection:** Solvent cement socket, threaded, flanged, fusion spigot, fusion socket
- **Mounting:** Stainless steel threaded inserts
- **Set Pressure Range:** 7-150psi
- **Hysteresis:** Approx. 1.5–5.8 psi
- **Standard Pack Quantity:** 1 valve

Key Certifications

- **FDA CFR 21 177.1520:** PP and PVDF
- **FDA CFR 21 177.2600:** EPDM and FPM
- **FDA CFR 21 177.1550:** PTFE
- **USP 25 Class VI (physiological non-toxic):** PP and PVDF
- **ABS:** All materials

Sample Specification

The Type 586 Pressure Retaining Valve shall control upstream pressure and be positive shutoff. The set pressure shall be controlled via an adjustment screw. The body shall be fully molded. The spindle shall be of non-rising design. The bonnet connection shall be of threaded design. The seal material shall be indicated by the color of an external tab. ANSI versions shall meet ANSI B16.5 150lb standards. All valves shall be tested in accordance to ISO9393. All valves shall be manufactured under ISO9001 for Quality and ISO14001 for Environmental Management. Following assembly, every valve shall be tested and certified bubble tight exceeding Class VI standards.

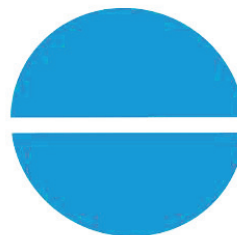

Material Specification

PVC valves shall meet ASTM D1784 cell classification 12454 standards. CPVC valves shall meet ASTM D1784 cell classification 23447-B standards. PP valves shall meet ASTM D5847-14 cell classification PP0510B66851 standards. PVDF valves shall be type 1, grade 2 according to ASTM D3222 standards. Valves of all materials shall be RoHS compliant.

Valve Function

The pressure retaining valve maintains the line pressure to a set value on the valve inlet. The inlet pressure is in direct relation to the flow. Independent of pressure fluctuations, the system pressure stays largely constant. The Type 586 can be used in relief applications in combination with a tee.

Components

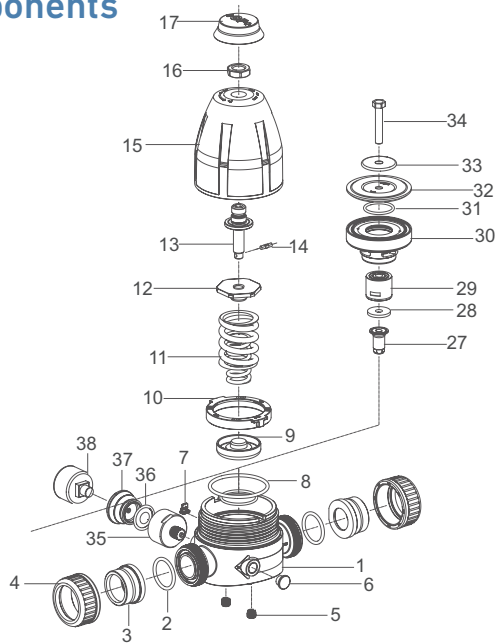

Optional Features

- **Gauge:** SS304, Brass
- **Gauge Guard:** PVDF/EPDM, PVDF/FPM
- **End Connection:** Alternatives available upon request
- **Set Pressure Range:** 4-44psi
- **Cleaned:** Silicone free/oil free
- **High Purity:** PVDF

Material Availability

- **3/8" (d16)** - PVC metric spigot (adapter unions available)
- **1/2"-2" (d20-d63)** - All material/end connections

Part	Description	Material
1	Valve body	PVC, CPVC, PP or PVDF
2	Face seal	EPDM or FPM
3	Union end	PVC, CPVC, PP, PPn, ABS, PE or PVDF
4	Union nut	PVC, CPVC, PP or PVDF
5	Threaded insert	304 stainless steel
6	Gauge port plug	Glass-filled PP
7	Indicator tab	Glass-filled PP
8	Cartridge seal set	EPDM or FPM
9	Pressure piece	304 stainless steel
10	Retaining ring	Glass-filled PP
11	Spring set	Steel EN10270-1SH (C) Deltatone coated
12	Spring retainer	Brass
13	Spindle	304 stainless steel
14	Spindle pin	304 stainless steel
15	Bonnet	Glass-filled PP
16	Adjustment screw nut	304 stainless steel
17	Protective cap	Glass-filled PP
27	Piston	PVC, CPVC, PP or PVDF
28	Cartridge flat gasket	EPDM or FPM
29	Piston housing	PVC, CPVC, PP or PVDF
30	Cartridge	PVC, CPVC, PP or PVDF
31	Piston seal	EPDM or FPM
32	Diaphragm	PTFE/EPDM
33	Diaphragm plate	304 stainless steel
34	Cartridge bolt	304 stainless steel

Technical Data

The following information is based on a 25 year lifetime water or similar media application

Cv Values

Size (Inch)	d (mm)	Cv (gal/min)
3/8	16	3.5
1/2	20	3.6
3/4	25	7.9
1	32	8.6
1 1/4	40	18.1
1 1/2	50	19.7
2	63	20.2

Pressure-Temperature

Material	Temperature Range (°F)	Max Pressure (psi)
PVC	32 to 140	150
CPVC	32 to 176	150
PP	32 to 176	150
PVDF	-4 to 284	150

Pressure Temperature Curves

The following graphs are based on a 25 year lifetime water or similar media application

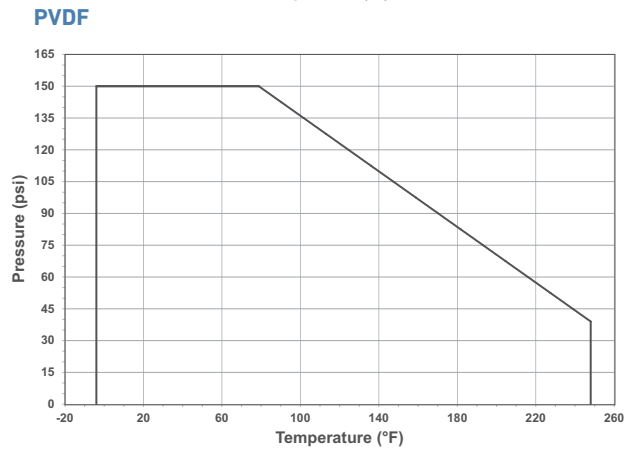
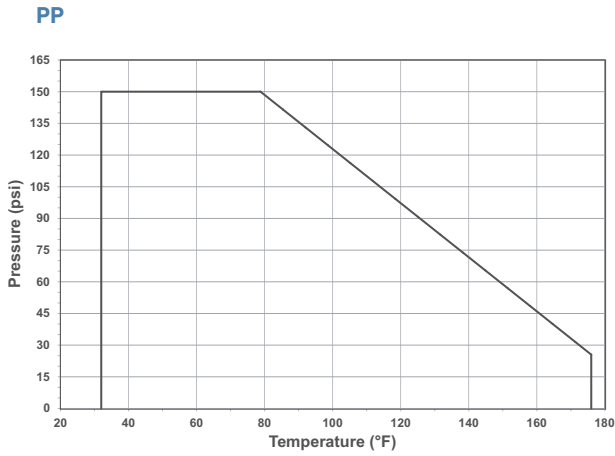
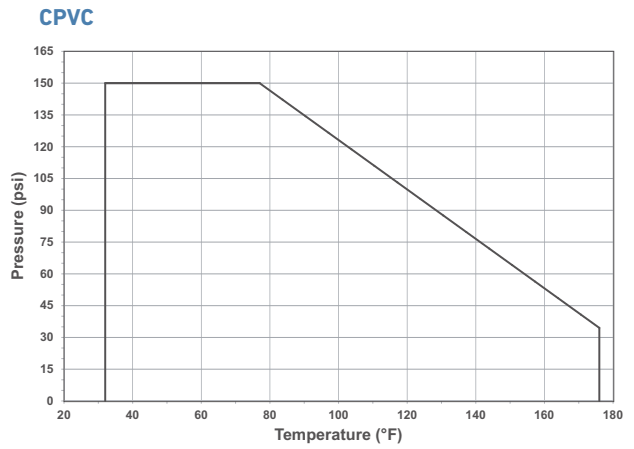
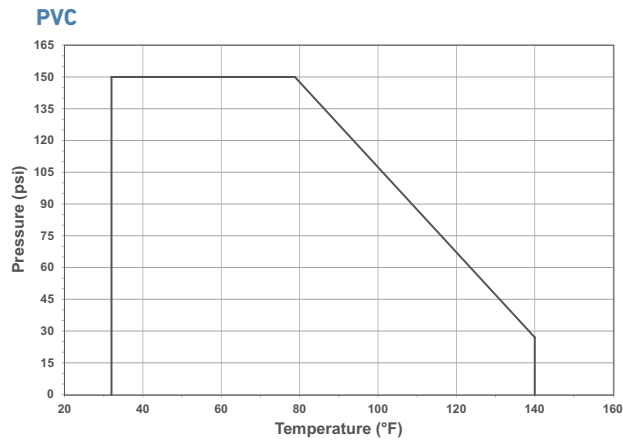

Valve Sizing

Hysteresis Curve

The curves below are valid for the set range 7–150 psi and show the secondary or outlet pressure P2 over the flow Q in gal/min. Parameter is the set pressure pE at Q = 0 gal/min. These curves are valid for water at 70°F for a flow velocity of 6.6 ft/s.

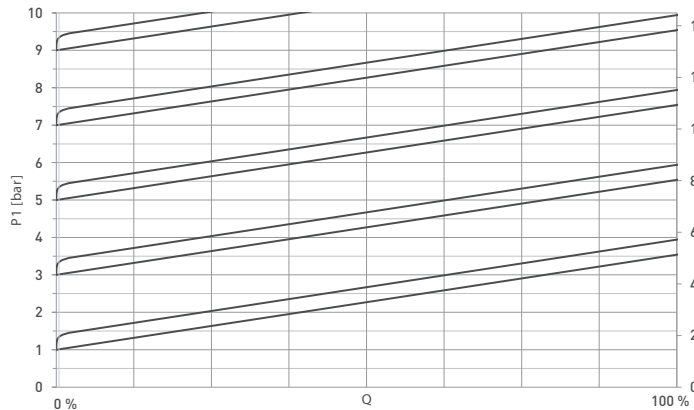

100% corresponds to a flow velocity of 6.6 ft/s

Max Flow Rates

Size	l/h	gpm
d16 (5/8")	1,000	4.4
d20 (1/2")	1,600	7.0
d25 (3/4")	2,500	11.0
d32 (1")	4,000	17.6
d40 (1 1/4")	6,000	26.4
d50 (1 1/2")	10,000	44.0
d63 (2")	16,000	70.4

On the left, you see the schematic diagrams of the hysteresis curve. The table above shows the maximum values at 100% in the diagram.

Dimensions

The following tables are shown in millimeters unless otherwise specified

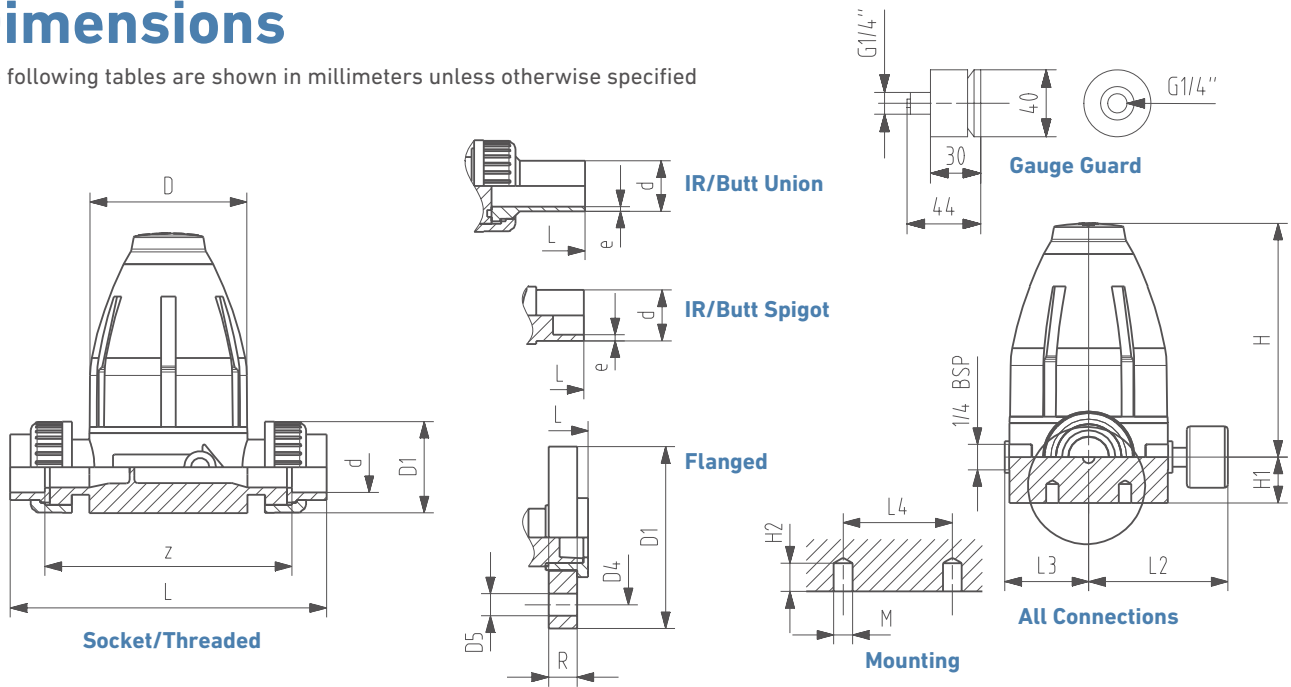

All Materials

Size (inch)	d (mm)	D	D1	H	H2	L2	L3	L4	M
3/8	16	79	43	111	12	77	42	45	M6
1/2	20	79	43	111	12	77	42	45	M6
3/4	25	100	51	148	12	88	53	45	M6
1	32	100	58	148	12	88	53	45	M6
1 1/4	40	147	72	207	15	111	76	70	M8
1 1/2	50	147	83	207	15	111	76	70	M8
2	63	147	101	207	15	111	76	70	M8

PVC/CPVC

Size (inch)	IPS Socket		Threaded NPT		ANSI Flanged				
	L	z	L	z	L	D1 (inch)	D4 (inch)	D5 (inch)	R (inch)
1/2	171	126	163	124	140	3.74	2.36	0.63	0.6
3/4	207	156	198	157	180	4.13	2.76	0.63	0.7
1	214	156	203	155	180	4.53	3.11	0.63	0.7
1 1/4	275	211	269	213	229	5.51	3.5	0.63	0.8
1 1/2	281	211	272	226	229	5.91	3.86	0.63	0.9
2	288	211	284	239	249	6.5	4.76	0.75	0.9

PP

d (mm)	IR/Butt Fusion Union		IR/Butt Fusion Spigot		Socket Fusion Union	
	L	e	L	e	L	z
20	228	1.9	150	1.9	158	126
25	264	2.3	190	2.3	192	156
32	270	2.9	190	2.9	196	156
40	331	3.7	240	3.7	255	211
50	337	4.6	240	4.6	261	211
63	343	5.8	259	5.8	269	211

PVDF

d (mm)	IR/Butt Fusion Union		IR/Butt Fusion Spigot		Socket Fusion Union	
	L	e	L	e	L	z
20	226	1.9	150	1.9	158	130
25	262	1.9	190	1.9	192	160
32	268	2.4	190	2.4	196	160
40	329	2.4	240	2.4	255	215
50	335	3	240	3	261	215
63	340	3	260	3	269	215