



TW Series Three-Way True Union Ball Valves

1/2" TO 6" PVC AND CPVC

KEY FEATURES

- PVC and CPVC
- Position Indicator
- Easily Actuated
- PTFE Seats
- FPM or EPDM O-Rings
- Double O-Ring Stem Seal

OPTIONS

- Lockouts Available
- Pneumatic and Electric Actuators
- Cross-Flow Ball
- TN Ball
- TP Ball

MATERIALS

- PVC Cell Class 12454 per ASTM D1784
- CPVC Cell Class 23447 per ASTM D1784
- FPM and EPDM O-Ring Seals

TECHNICAL INFORMATION

EXPLODED VIEW

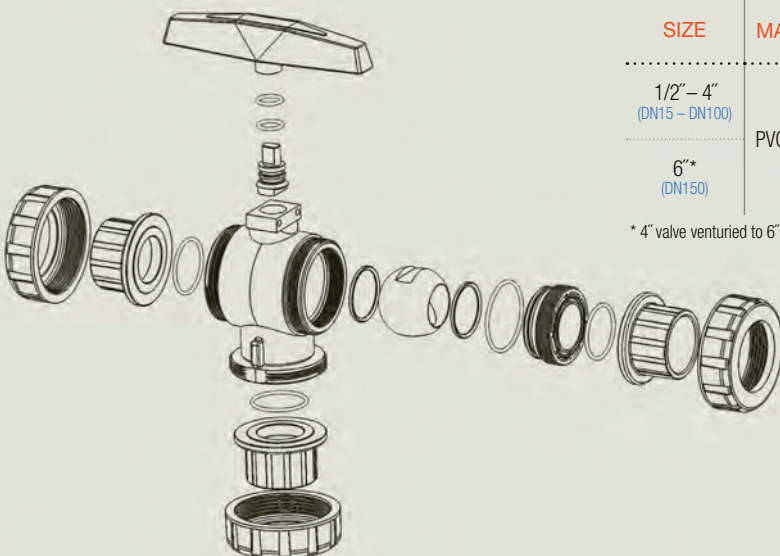

SELECTION CHART

SIZE	MATERIAL	END CONNECTION	SEALS	PRESSURE RATING
1/2" – 4" (DN15 – DN100)	PVC or CPVC	Socket, Threaded or Flanged	FPM or EPDM	150 PSI @ 70°F Non-Shock
6"* (DN150)		Flanged		

* 4" valve venturied to 6"

TW Series Three-Way True Union Ball Valves

1/2" TO 6" PVC AND CPVC

TECHNICAL INFORMATION, CONTINUED

PARTS LIST

1. Actuation Mount
2. O-Ring Seals
3. End Connector
4. Assembly Nut
5. PTFE Seats
6. Body
7. Ball
8. Stem

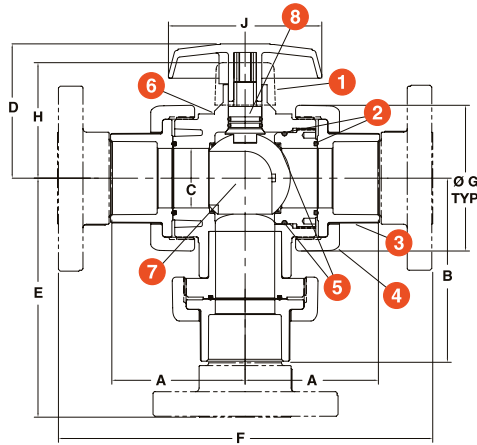

OPERATING TEMPERATURE/PRESSURE

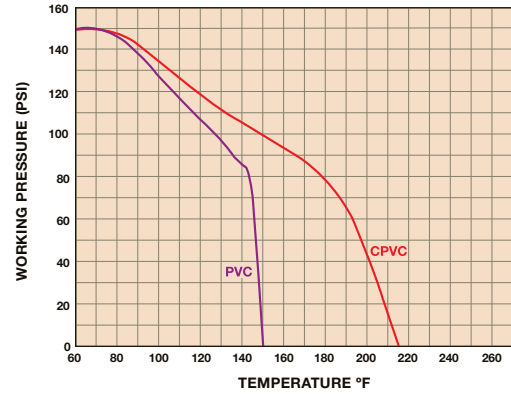

DIMENSIONS

SIZE in/DN	A in/mm	B in/mm	C in/mm	D in/mm	E in/mm	F in/mm	G in/mm	H in/mm	J in/mm
1/2/15	2.30/58	3.29/84	0.50/13	2.94/75	3.87/98	6.72/171	2.25/57	2.53/64	3.50/89
3/4/20	2.56/65	3.57/91	0.75/19	2.97/75	4.60/117	7.50/191	2.63/67	2.82/72	3.50/89
1/25	2.98/76	4.14/105	1.00/25	3.21/82	4.77/121	8.50/216	3.00/76	3.08/78	4.00/102
1-1/4/32	4.39/112	5.94/151	2.00/51	3.63/92	5.19/132	11.54/293	4.00/102	3.50/89	4.00/102
1-1/2/40	4.30/109	5.87/149	2.00/51	3.63/92	6.00/152	11.85/301	4.00/102	3.50/89	4.00/102
2/50	4.38/111	6.00/152	2.00/51	4.31/109	6.75/171	12.25/311	4.75/121	3.95/100	5.00/127
2-1/2/65	5.90/150	7.59/193	3.00/76	7.02/178	8.68/220	15.92/404	6.40/163	5.88/149	10.50/267
3/80	5.90/150	7.59/193	3.00/76	7.02/178	8.72/221	16.00/406	6.40/163	5.88/149	10.50/267
4/100	7.00/178	9.33/237	4.00/102	8.02/204	10.44/265	18.88/480	8.56/217	8.88/226	10.50/267
6/150	N/A	N/A	4.00/102	8.02/204	11.25/286	20.25/514	8.56/217	8.88/226	10.50/267

Dimensions are subject to change without notice – consult factory for installation information

Cv VALUES

SIZE in/DN	Cv VALUES	SIZE in/DN	Cv VALUES
1/2/15	3.0	2/50	58.0
3/4/20	7.0	3/80	190.0
1/25	10.0	4/100	450.0
1-1/2/40	30.0	6/150	340.0

FLOW SCHEMATICS – TOP VIEW

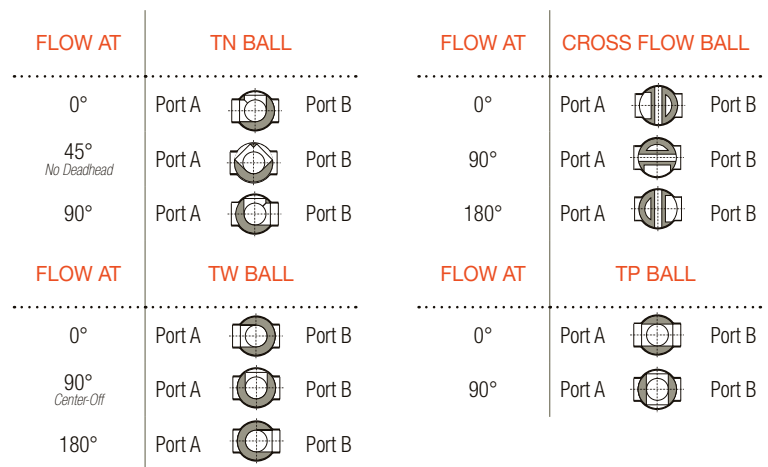

PRESSURE LOSS CALCULATION FORMULA

$$\Delta P = \left[\frac{Q}{C_v} \right]^2$$

ΔP = Pressure Drop
 Q = Flow in GPM
 C_v = Flow Coefficient



Contact Hayward Flow Control with questions: **USA:** 1-888-429-4635 • Fax: 1-888-778-8410 • One Hayward Industrial Drive • Clemmons, NC 27012 USA
Canada: 1.888.238.7665 • Fax: 1.905.829.3636 • 2880 Plymouth Drive • Oakville, ON L6H 5R4 Canada • Email: hflowcanada@haywardnet.com
 Visit us at: www.haywardflowcontrol.com • E-mail: hflow@haywardnet.com