

# UltraPro® Series Ultrasonic Level Sensor

## Operating Manual

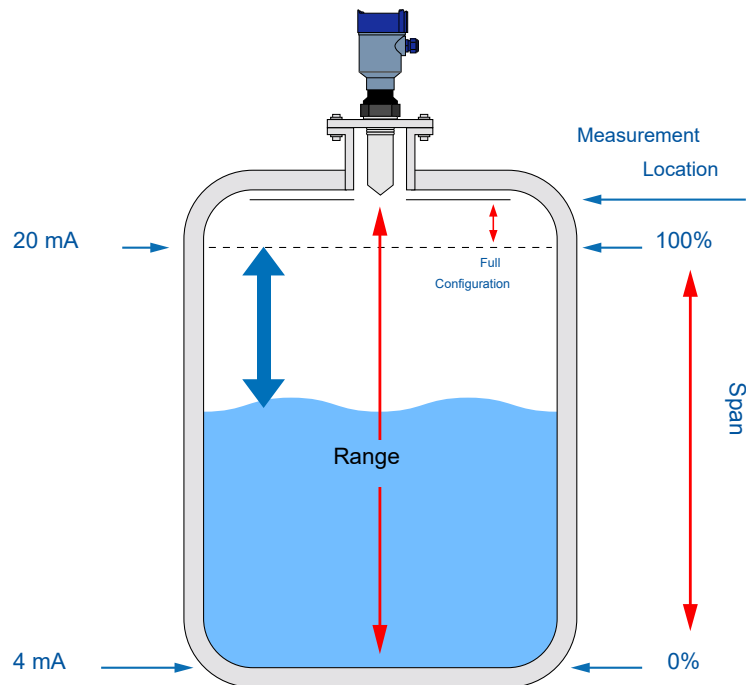

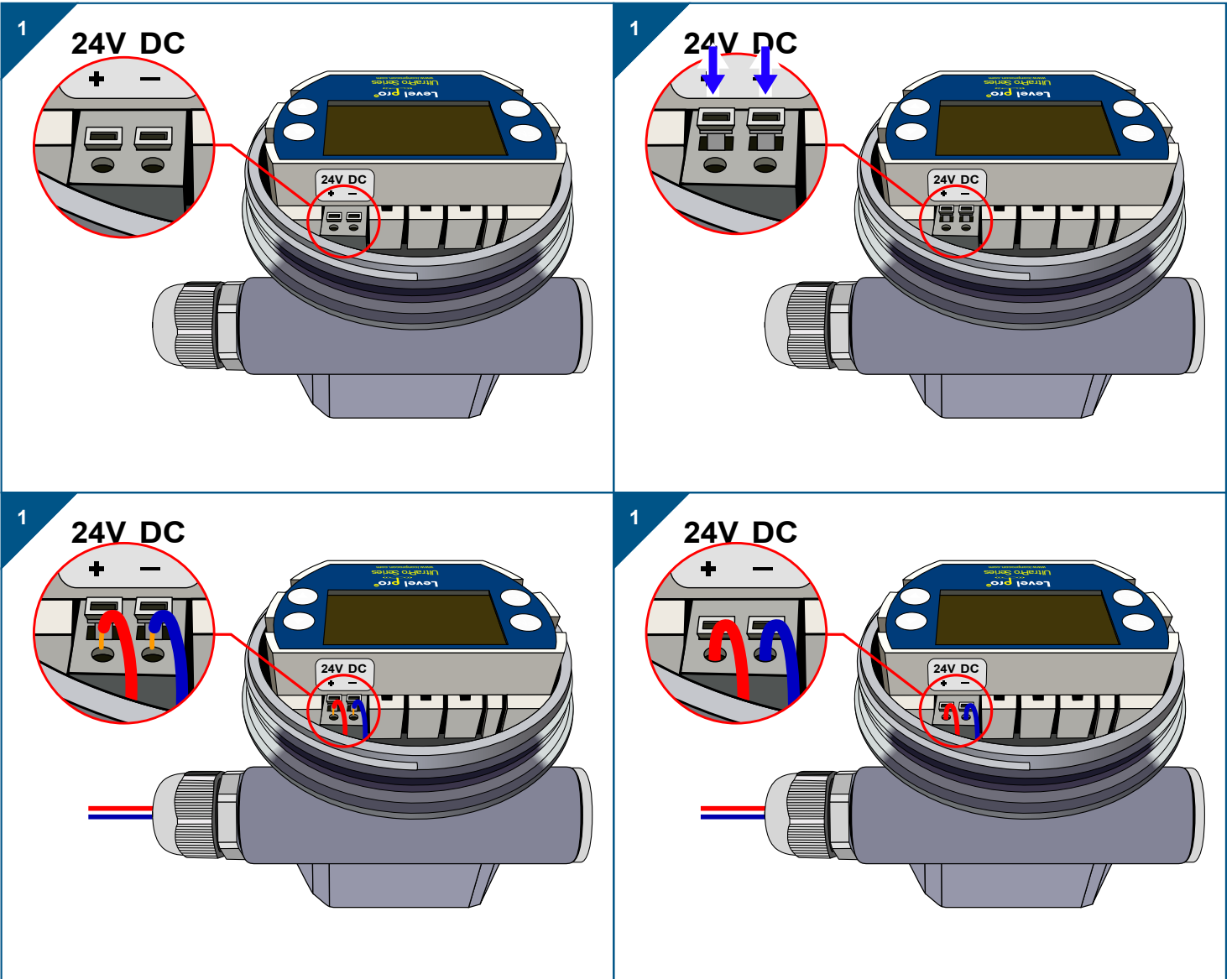

### 1. Introduction

The UltraPro Series ultrasonic level sensor is a non contact type high precision level measuring instrument that is user friendly and requires no maintenance. It should be used on relatively easy process conditions with varying liquid media consistencies.

### 2. Getting Started

Since installation conditions vary some basic information will be required:

1. Overall Tank Height
2. High Level Point
3. Empty or Zero Level Point



#### Button Functions:

1. Enter into menus
2. Quit the menu
3. Confirm the parameters change.

#### 1. Move the cursor

#### 2. Modify the parameter



#### 3. Choose menu



#### 2.1 Enter into menu



Long press the set button (SET) for 2s to enter in the main menu. The menu modes include expert setting mode and simply setting mode. The menu query table of simple setting mode is as shown in the table below.

## Quick Start Programming

### 2. Select the Measurement Mode

Measuring modes are divided into distance measuring mode and material level measuring mode. And the factory default is material level measurement.

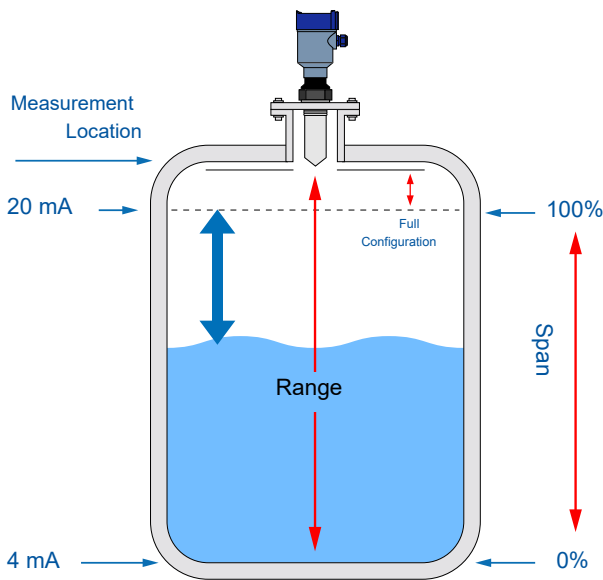
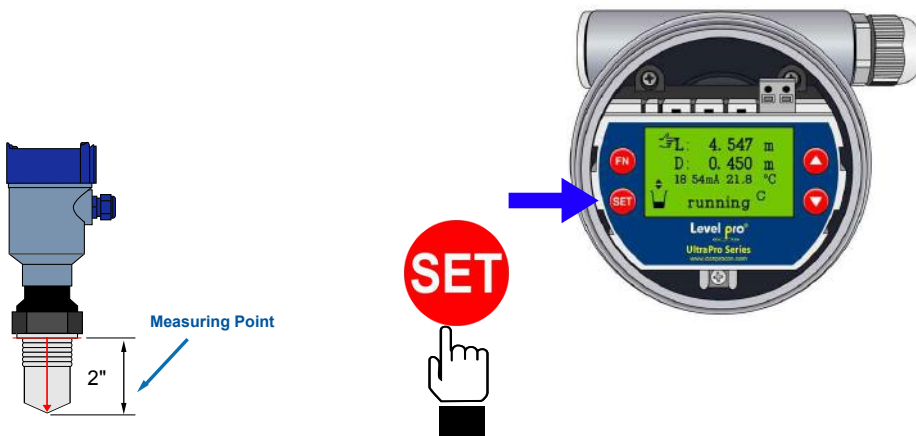

Parameter Setting

Enter distance transducer to tank bottom

This is Overall Measuring Range of Sensor 5m or 10m

Enter Low or Empty  
Factory Default = 0

Enter High or Full  
Number must be below  
5m for 5m Sensor  
10m for 10m Sensor

Programming Complete

Press SET to ENTER

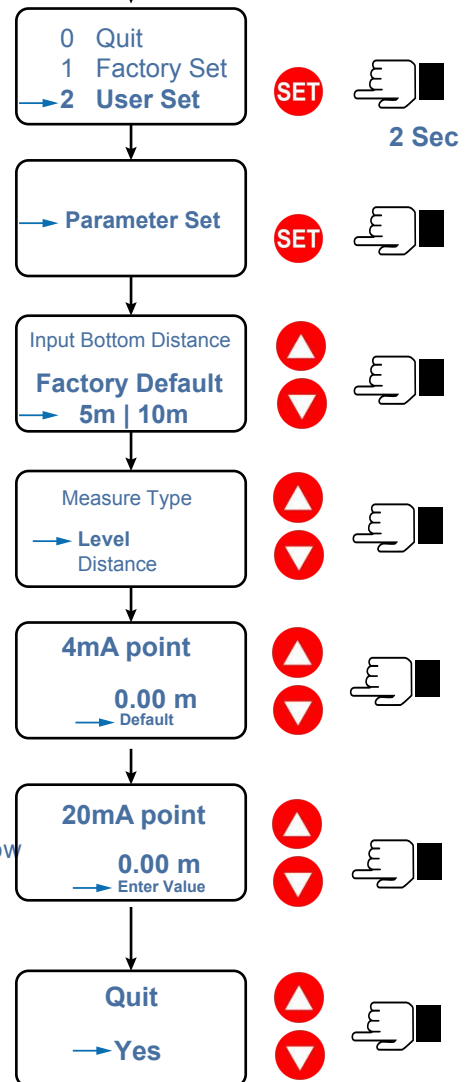

### Liquid Measurement

#### Flat-top tank

Normally, the flat-top tank has a short connecting pipe whose datum plane is the under surface of flange. Under the premise that the connecting pipe length is  $\leq 60\text{mm}$ , inner diameter is  $\geq 100\text{mm}$  and inner wall is smooth and free of burr and bulges, the measurement can be carried out if the emitting surface of installed probe is 3cm below the flange under surface.

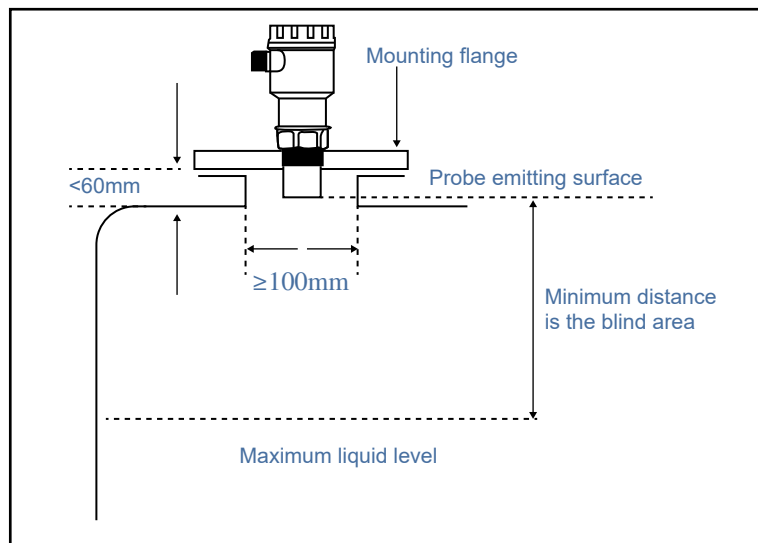

The most ideal installation is to directly install the meter on the flat-top container without using the connecting pipe and the round opening on the container is good enough for the fixing of mounting flange. The probe emitting surface is below the datum plane.

#### Understand Terminology

- ① Measuring range: the meaning of measuring range is very important for meter type selection. Please refer to the diagrams below.

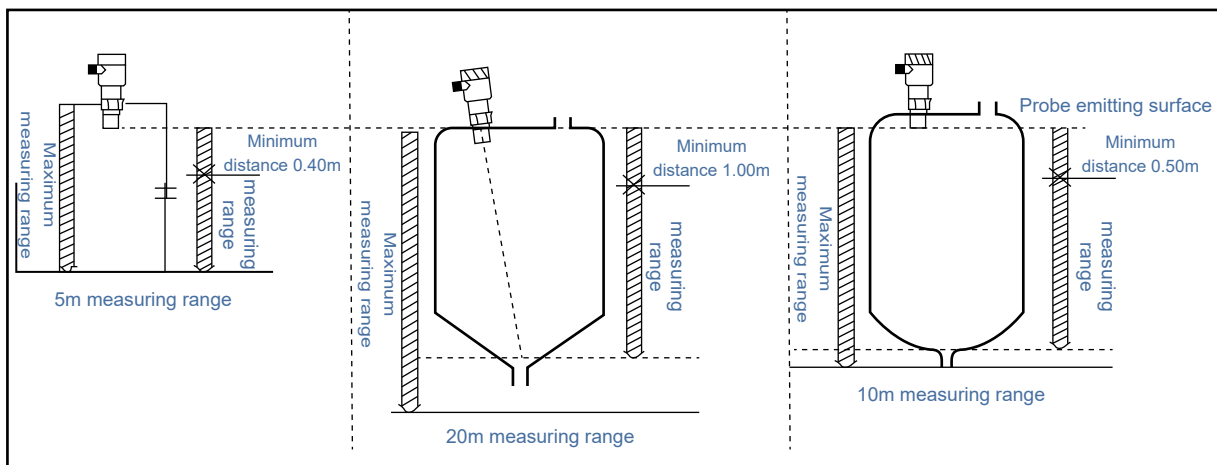

Ultrasonic wave beam is gathered by the probe. The emitting of impulse wave beam is like the light beam of flashlight. The further it is from the probe, the greater the diffusion area is.

2.4 Diagram of distance mode and level mode

Under distance measuring mode, setting of reference zero point is meaningless and the positions of maximum of measuring range and minimum of measuring range are as shown in Fig. 1.1

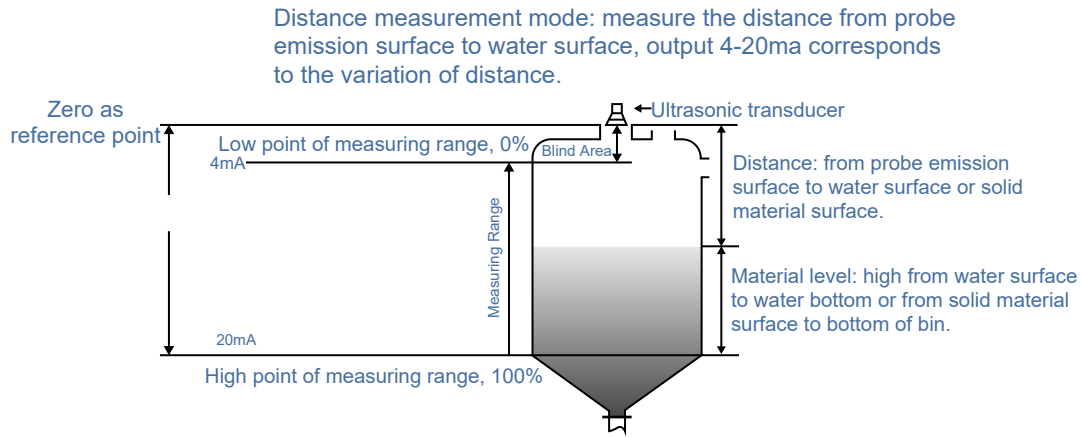

Fig. 1.1 Diagram of Distance Measurement

Under material level measuring mode, the positions of reference zero point, maximum of measuring range and minimum of measuring range are as shown in Fig. 1.2

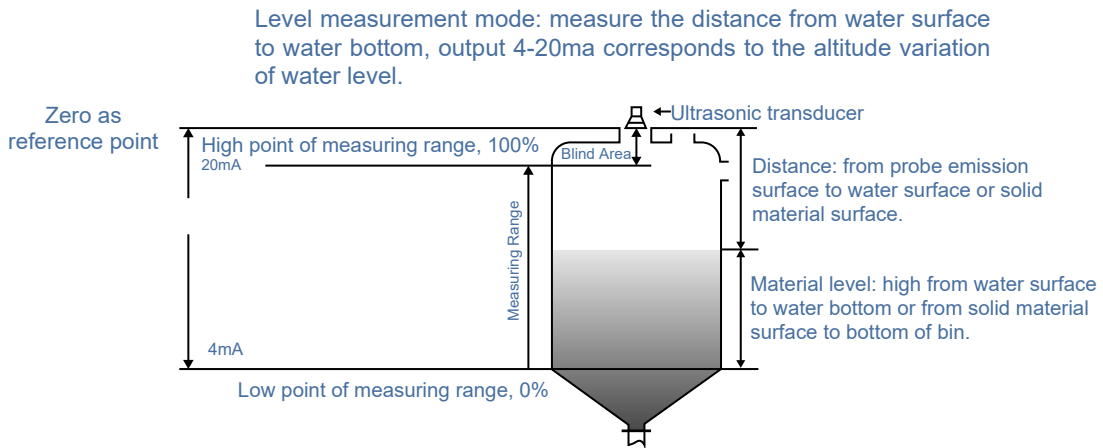

Fig. 1.2 Diagram of Material Measurement Level

### 3. Main technical parameters

Function	Parameters
Measuring range	5m   10m
Accuracy	0.5%
Resolution	2mm or 0.1% (whichever is greater)
Display	LCD
Analog output	2-Wire system 4~20mA/250Ω load
Relay	(i.e. AC 250V/ 8A or DC 30V/ 5A) optional
Power supply	Standard 24V DC Optional: 120V AC +15% 50Hz
Ambient temperature	Display instrument:-20~+60°C Probe: -20~+80°C
Communication	4-20mA   RS 485 Optional
IP grade	Display instrument: IP66, probe: IP68

Any objects within the range of emitting angle, such as pipe, support, weld joint, reinforcing rib, mixing propeller and hanging object, will lead to strong false echo, specially the objects within the range of emitting angle which are near the probe.

For example, the false echo caused by the pipe at 6m from the probe is 9 times stronger than that caused by the same pipe at 18m from the probe.

- ★ Try every effort to make the sensor axis perpendicular to the medium surface and avoid any other object within the range of emitting angle, such as pipe and support.

## Liquid Measurement

### Flat-top tank

Normally, the flat-top tank has a short connecting pipe whose datum plane is the under surface of flange. Under the premise that the connecting pipe length is  $\leq 60\text{mm}$ , inner diameter is  $\geq 100\text{mm}$  and inner wall is smooth and free of burr and bulges, the measurement can be carried out if the emitting surface of installed probe is 3cm below the flange under surface.

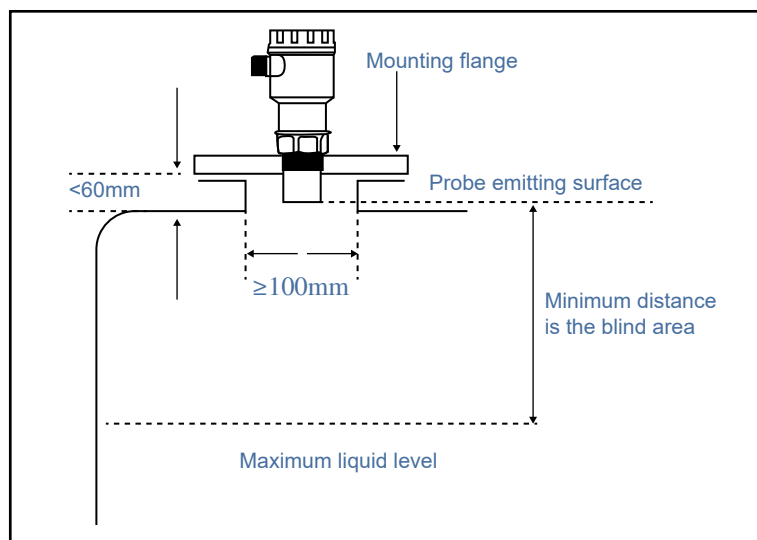

The most ideal installation is to directly install the meter on the flat-top container without using the connecting pipe and the round opening on the container is good enough for the fixing of mounting flange or cardan joint. The probe emitting surface is below the datum plane.



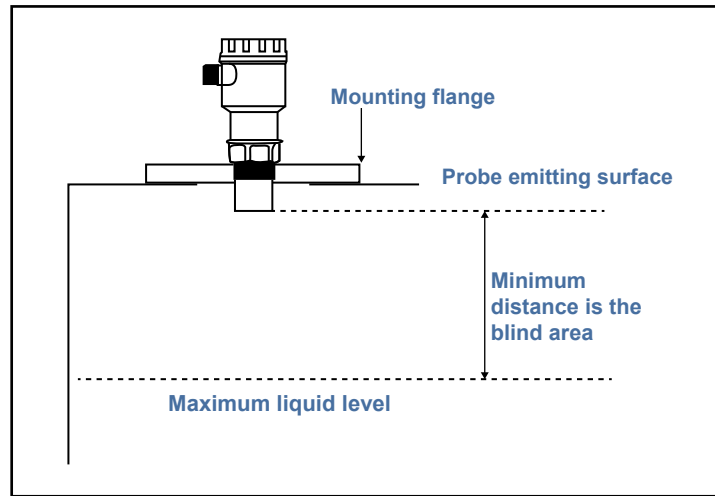

Flange-type installation on the flat-top tank

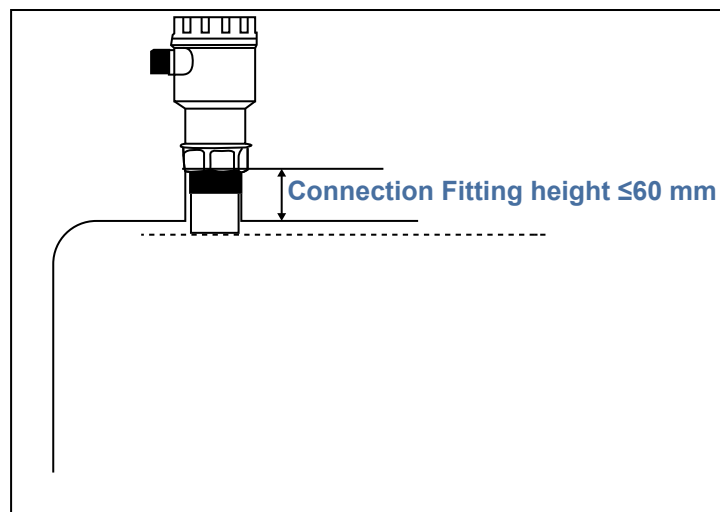
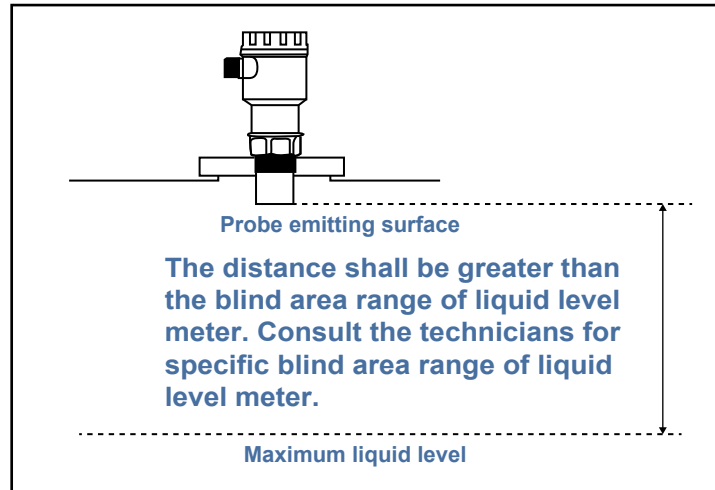

#### 4.2 Round Top Tank

For round top tank the sensor should be installed at 1/2 or 2/3 of the tank top radius ensuring that necessary distance from the tank wall is met. The arch tank top is like convex lens to the ultrasonic pulse. If the probe is installed at the focus of convex lens, it will receive all the false echoes.

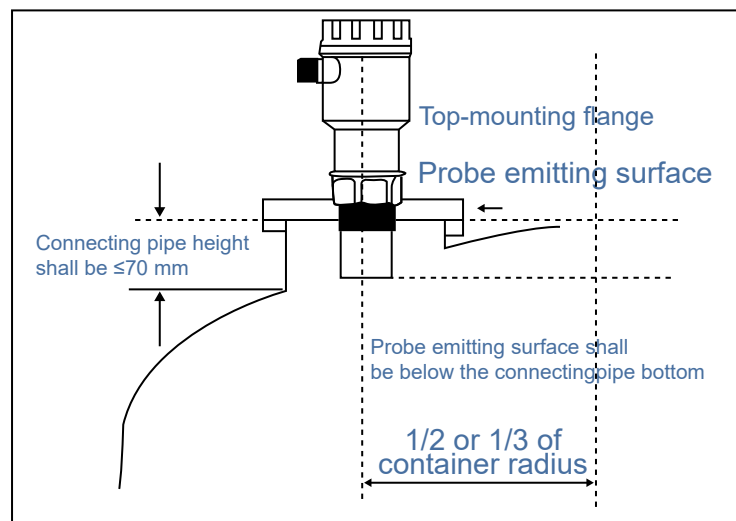
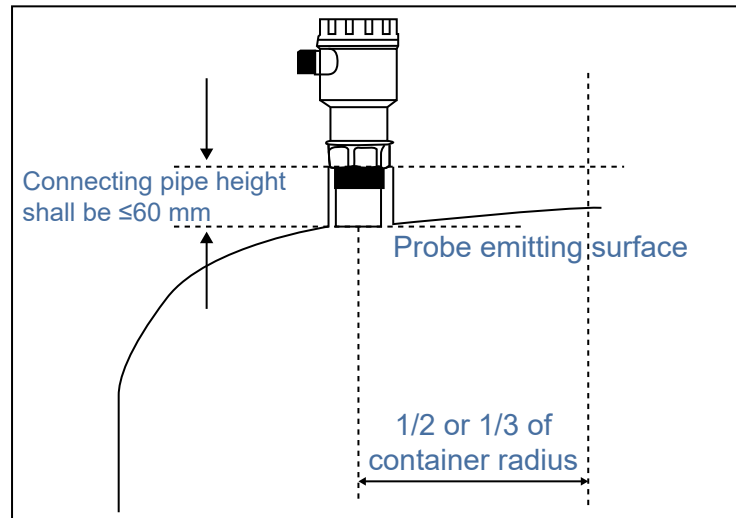

For most arch tanks, the length of connecting pipe plus flange on the top is 150-180mm. But the part below the probe thread of ultrasonic level meter is not so long (elongated probe is available for customization to make sure the probe emitting surface is below the connecting pipe bottom). In this case, the proportional relation between the diameter and length of connecting pipe shall be noted.

S/N	Length of Connecting Pipe	Minimum Inner Diameter of Connecting Pipe	Remarks
1	150mm	100mm	The inner wall of connecting pipe is free of burr and bulges and vertical and thr weld joint shall be polished. Thr connection of connecting pipe and tank top shall be outwards polished at an oblique angle of 45°.
2	200mm	150mm	
3	250mm	180mm	
4	300mm	220mm	
5	400mm	280mm	

4.2.4.3 Open container

For open container, the support shall be used for installation. The bearing capacity of support shall be noted and certain distance shall be kept between the sensor and container wall. If the upper part and lower part of the open container or stock bin inner wall are flat and free of hanging objects and any other objects, the distance between the sensor and container wall is detailed as follows:

Maximum Measuring Range	Minimum Distance to Wall	Maximum Measuring Range	Minimum Distance to Wall	Maximum Measuring Range	Minimum Distance to Wall
5m	0.5m	10m	1.0m	15m	1.5m
20m	2.5m	30m	3.5m	40m	5m
50m	6m	60m	7m	70m	8m

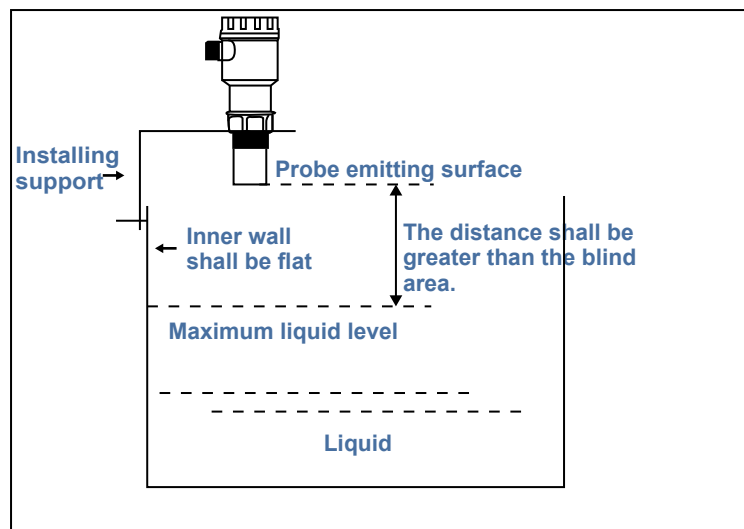

As the open container has no focusing effect, the sensor can be installed in the middle of the container.

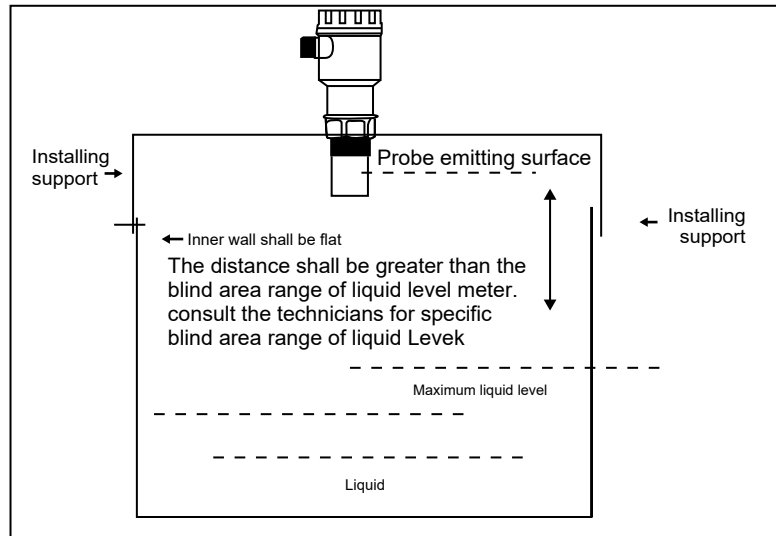

#### 4.2.4.4 Draining well and common well

Normally, the wellhole and wellhead of drainage well are narrow and the well wall is uneven, which makes it difficult to conduct ultrasonic measurement. This can be solved by installing a section of connecting pipe or a whole measuring casing. Attention shall be paid to the fact that the blind area will be enlarged for about 50~100% after the sensor is put into the connecting pipe. So the factors for blind area expansion shall be considered.

Thus, when the connecting pipe is used, if the original probe blind area is 0.50m, it will be enlarged to 1.00m after the probe is put into the connecting pipe.

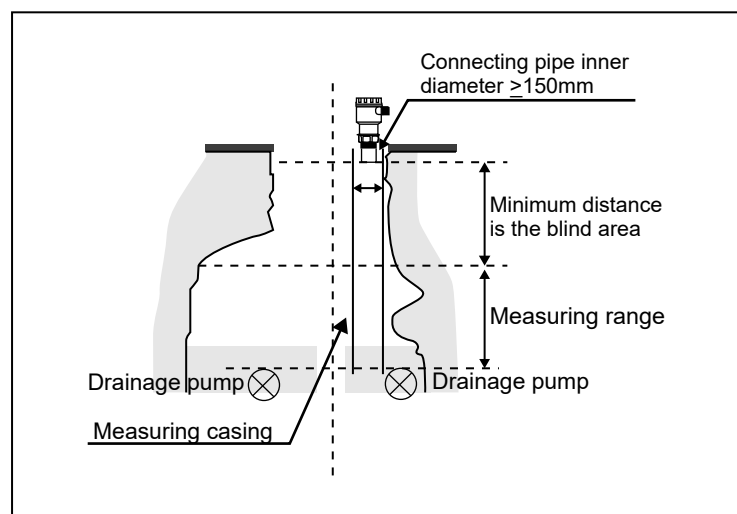

## 6. Faults and Handling

Faults	Causes	Handling
<p>UltraPro works but there is no change of trumpet icon on (▲) the LCD, which system is in wave loss state.</p>	<ol style="list-style-type: none"> <li>1. The measured area is beyond the measuring range of sensor</li> <li>2. The measured medium has strong disturbance, vibration or vapor.</li> <li>3. There are strong interference sources around such as frequency converter and motor.</li> <li>4. The probe is not perpendicular to the measured surface.</li> <li>5. There are objects in the measured space. ex. ladders, rods etc</li> <li>6. The liquid level is in a blind area.</li> </ol>	<ol style="list-style-type: none"> <li>1. Replace the level meter with a level meter with greater measuring range.</li> <li>2. The meter will restore the normal measurement automatically after the measured medium gets back to calm.</li> <li>3. Check surrounding environment and realize good electromagnetic shielding. Do not share one power supply with frequency converter and motor, and make it grounded reliably.</li> <li>4. Reinstall probe and ensure it is perpendicular to liquid surface.</li> <li>5. Select an appropriate position for installation and prevent an interfering object.</li> <li>6. Raise the installation position of probe.</li> </ol>

