

SERIES "ARV" THERMOPLASTIC AIR RELEASE VALVE SELF-GUIDED POPPET ASSURES DEPENDABLE, REPETITIVE OPERATION



FEATURES:

- **Safety:** Allows safe expulsion of unwanted air in piping system.
- **Dependability:** Unique self-guided poppet assures minimal emission of system liquid prior to sealing.
- **Convenience:** Union simplifies valve inspection/removal with minimum piping breakdown.
- **Minimum Closing Pressure:** Closes at 0 PSI, as long as liquid is present. Valve closes as liquid rises, after virtually all unwanted air is forced out. Seals bubble-tight at system pressures as low as 10 psi (EPDM seals).
- **Cost Efficient:** Designed to improve system performance and competitively priced.
- **Superior Design:** Poppet seals more reliably than ball design; does not deform under pressure like a hollow ball.
- **Corrosion Resistant:** Top quality thermoplastics and elastomers resist chemical attack and protect system purity. No metal components in Series ARV.

DESCRIPTION

Series ARV is a normally-open valve. Until your system is pressurized, the valve is simply open, and air is present. As pressure builds within the system, unwanted air is forced to the highest point in the system, i.e., the normally-open air release valve. When pressure within the system exceeds atmospheric pressure, air is expelled. As liquid rises, the poppet becomes buoyant and eventually closes. (Note, minimum specific gravity of liquid must be .9 or higher). It is possible that trace amounts of air will remain in the system, depending on the rapidity with which the valve closes. It is also likely that some trace amounts of process liquid will be emitted. At system pressure of 10 PSI (with EPDM elastomer), the poppet will seal bubble-tight against the orifice. When pressure and liquid level drop, the valve will automatically re-open.*

The poppet is guided by a series of thermoplastic ribs within the valve. The poppet is a unique design by Plast-O-Matic Valves, Inc. that is engineered to provide a balance of buoyancy and sealability. This balanced poppet is the key to the superior performance of this valve: it is dense enough to permit

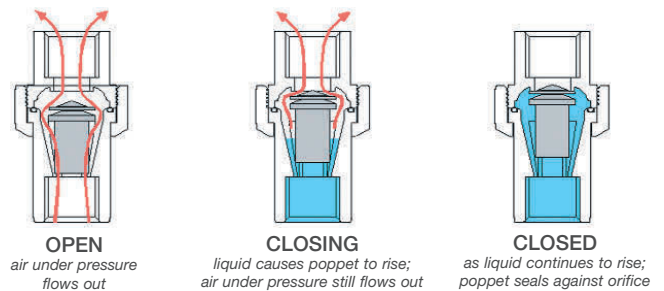

maximum emission of unwanted system air, yet buoyant enough to affect a quick seal and minimize emission of the process liquid. Historically, competitive air release valves have used ball-type sealing mechanisms that either seal too rapidly or allow excessive liquid to escape.

***Note:** Although Series ARV is a normally-open valve, it should not be used in lieu of a vacuum breaker due to safety considerations, such as continual emission of corrosive vapors.

INSTALLATION:

Series ARV should be installed at the highest possible point in a piping system or vessel, and it must be oriented upright. In most cases, residual liquid and/or vapor in the valve may be

expelled from the outlet port just prior to valve shut-off. Therefore, it is recommended to pipe the outlet port to a safe area for hazardous liquids, or use a standpipe for non-hazardous

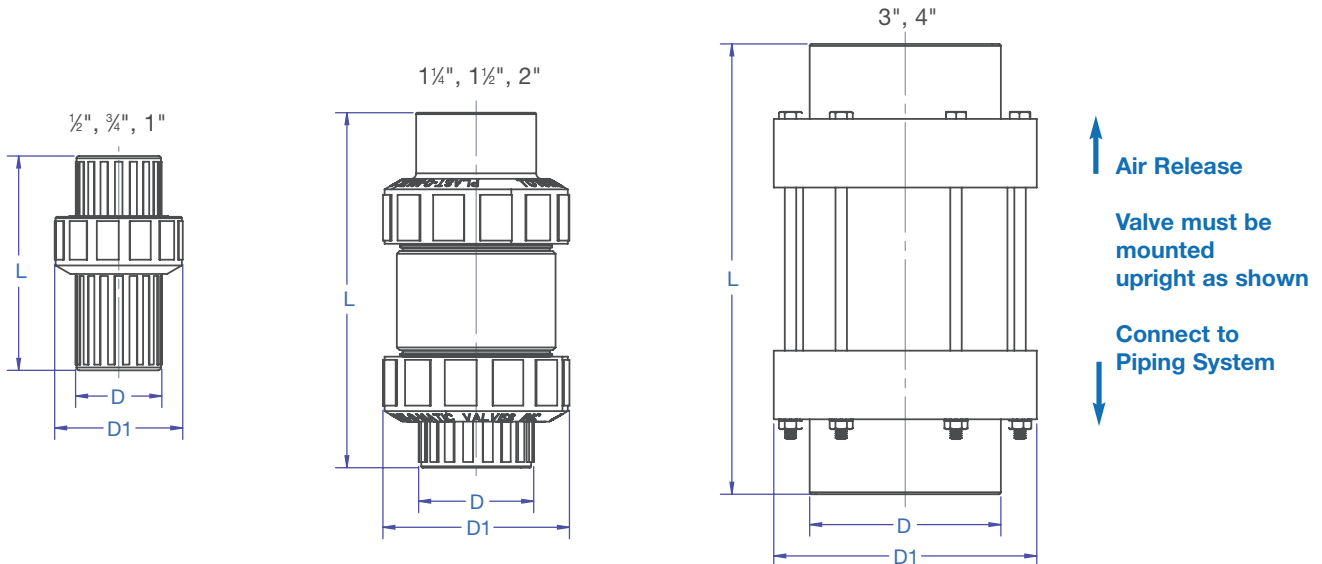

SERIES ARV – DIMENSIONS AND MODEL NUMBERS

PIPE SIZE NPT	L		D		D1		MODEL NUMBER	MAX. FLOW IN LINE SCFM	MAX. FLOW IN LINE GPM**
	in.	mm	in.	mm	in.	mm			
1/2"	5.3	130	1.9	48	2.8	72	ARV050EPT-PV	11	82
3/4"	5.3	130	1.9	48	2.8	72	ARV075EPT-PV	11	82
1"	4.7	120	1.9	48	2.8	72	ARV100EPT-PV	12	89
1 1/4"	7.8	197	2.5	64	4.1	103	ARV125EPT-PV	38	284
1 1/2"	7.8	197	2.5	64	4.1	103	ARV150EPT-PV	40	299
2"	8.4	214	3.0	76	4.1	103	ARV200EPT-PV	40	299
3"	9.8	250	4.2	106	5.8	146	ARV300EPT-PV	75	560
4"	11.7	298	5.8	146	7.9	200	ARV400EPT-PV	220	1645

ARV(series) 050 (size) EP (material) T (threaded) - PV (body material).
Part numbers shown are EPDM seals with PVC bodies.

- For FKM seals, change "EP" to "V" (ARV050VT-PV).
- For Corzan CPVC, change "-PV" to "-CP" (ARV050VT-CP).
- Standard connections are threaded. For socket connection, change "T" to "S" after seal material (ARV050EPS-PV)
- For spigot or other connection types, consult factory.
- For optional dust cap, consult factory.

** Note that excess of maximum pipeline GPM, airflow out of the valve will have sufficient force to lift and close the poppet, even though more air may be in the system. Liquid pumping into the system at flow rate exceeding maximum GPM will create air flow in excess of maximum SCFM.

ADDITIONAL SPECIFICATIONS

Pressure required for bubble-tight seal	EPDM Elastomer: 10 PSI	FKM Elastomer 15-20 PSI
Pressure Rating at 75°F (24°C)	150 PSI	